



PACi

A photograph of a modern clothing store interior. The scene is dimly lit, with spotlights highlighting various clothing items. In the foreground, a rack of clothes is visible, including a white t-shirt with a colorful graphic and a grey sweater. Above the rack, a shelf holds folded purple clothing. The background shows more racks and shelves, creating a sense of depth. The overall atmosphere is clean and contemporary.

WELCOME TO THE COMMERCIAL RANGE

Here are some of your new air conditioner's major features.

Panasonic has developed an impressive range of highly efficient Commercial Air Conditioners. This range confirms our commitment to the environment. Our Inverter compressors optimise performance and thus reduce energy costs.



PACi

Highlighted Features

PACi Standard: For economy and value

With high quality design and engineering, the PACi Standard is the perfect solution for projects which demand quality on a limited budget. In addition, its compact size and light weight make it ideal for installations with limited space including small commercial and residential applications.

PACi Elite: Newly designed next generation of commercial air conditioning

Energy-saving concept. The use of energy saving design for the structure of fans, fan motors, compressors and heat exchangers resulted in high COP value which ranked as one the top class in the industry. In addition, use of highly efficient R410A refrigerant reduces CO₂ emission and lowers operating costs.



ENERGY SAVING



Intelligent Human Activity Sensor and new Sunlight Sensor technologies that can detect and reduce waste by optimising air conditioner operation according to room conditions. With just one touch of a button, you can save energy.

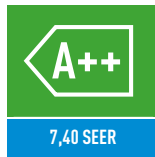

Exceptional Seasonal Cooling Efficiency based on the new ErP regulation. Higher SEER ratings mean greater efficiency. Save all the year while cooling!



Exceptional Seasonal Heating Efficiency based on the new ErP regulation. Higher SCOP ratings mean greater efficiency. Save all the year while heating!



Inverter plus products improve on the characteristics of standard Inverter range by over 20%. This means 20% less consumption and 20% off your electric bill. A Inverter plus is also A class on cooling and heating mode.

HIGH PERFORMANCE



The air conditioner works in cooling only mode with an outdoor temperature of -15°C .



The air conditioner works in heat pump mode even when outdoor temperatures are low as -20°C or -15°C .



DC Fan: Save and precise.

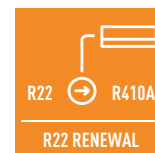

The Panasonic renewal system allows good quality existing R22 pipe work to be re-used whilst installing new high efficiency R410A systems.



5 years warranty. We guarantee the outdoor unit compressors in the entire range for five years.

HIGH CONNECTIVITY



The new Cloud system from Panasonic allows you to have complete control of all your installations. In a simple click, all your units from several locations, receive status updates in real-time of all your installations, preventing breakdowns and optimizing costs.



Internet Control is a next generation system providing a user-friendly remote control of air conditioning or heat pump units from everywhere, using a simple Android or iOS smartphone, tablet or PC via internet.

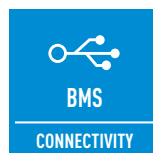

The communication port is integrated into the indoor unit and provides easy connection to, and control of, your Panasonic heat pump to your home or building management system.



PACi Standard and Elite

PACi Standard

- Good balance, system cost vs energy efficiency
- Top class SEER/SCOP as a Standard Inverter category
SEER: A++ / SCOP: A+ at 10.0 kW (in Cassette 90x90)
- Interchangeable controller with ECOi
- Compact outdoor units
- Twin connection possible
- Cooling operation up to -15°C
- Heating operation up to -10°C

PACi Elite

- Meeting all necessary safety approvals to ensure quality and safety
- Top-class SEER: A++ / SCOP: A+ at 10.0 kW (in Cassette 90x90 and Ceiling)
- Cooling operation is possible when outdoor temperature as high as 46°C
- DC inverter technology combined with R410A for excellent efficiency
- Cooling operation is possible when outdoor temperature as low as -15°C
- Heating operation is possible when outdoor temperature as low as -20°C
- Compact outdoor units
- Auto restart from outdoor unit
- Twin, Triple and Doble-Twin connection possible

SEASONAL EFFICIENCY SEER – SCOP
A++ **A+**



SEASONAL EFFICIENCY SEER – SCOP
A++ **A+**



PACi Standard: outdoor unit

More compact

The outdoor unit is much more compact than the previous model. The slim and lightweight design means the PACi outdoor unit can be installed in a number of situations.

* Only for U-100PEY1E8, U-125PEY1E8, U-100PEY1E5 and U-125PEY1E5.

**-15%
SMALLER**

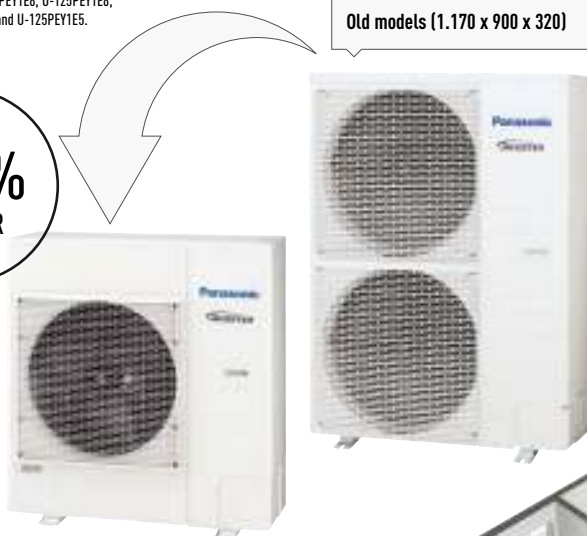

Old models (1.170 x 900 x 320)

On the 12,5 kW (996 x 940 x 340)

Product Quality and Safety

All Panasonic air conditioners undergo strict quality and safety tests before sale. This rigorous process includes obtaining all necessary safety approvals, to ensure that all air conditioners we sell are not only built to the highest market standards, but are also completely safe.

Quiet mode

2, 4 or 6 dB can be reduced by different setting on your choice. External input signal is also available.





PACi Elite outdoor units

Improved energy saving

Operating efficiency has been improved using highly efficient R410A refrigerant, new DC inverter compressor, new DC motor and a new heat exchanger design.

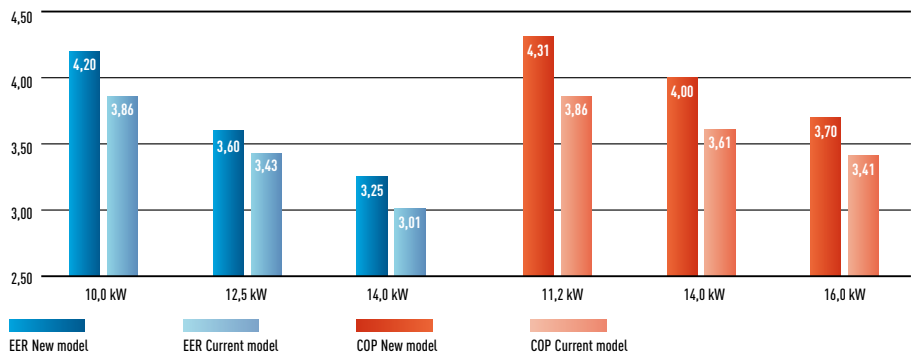

Wide operating range

Cooling operation is possible when outdoor temperature as low as -15°C or as high as 46°C. Heating operation is possible when outdoor temperature as low as -20°C. The remote control temperature setting offers a range from 18°C to 30°C.

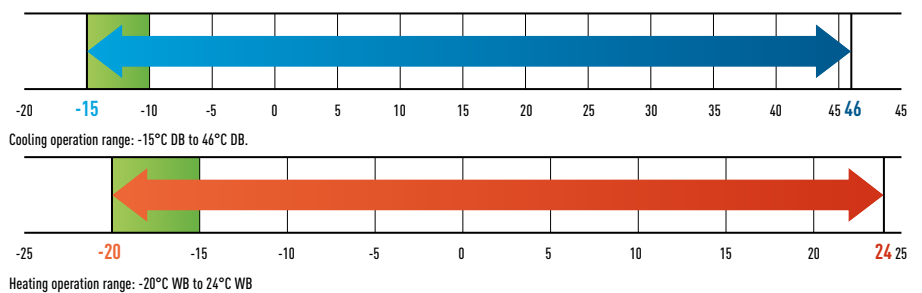

Energy saving concept

The use of energy saving designs for the structure of fans, fan motors, compressors and heat exchangers has resulted in a high COP value, ranked as one of the top classed in the industry. In addition, use of highly efficient R410A refrigerant reduces CO₂ emission and lowers operating costs.

1. Compact & highly efficient compressor. Large-capacity inverter compressor has been adopted. The inverter compressor is superior in performance with improved partial-load capacity.
2. Printed circuit board (P-LINK). To improve maintenance, the number of PCBs have been reduced to two.
3. DC fan motor. Considering load and outside temperature, the DC motor is controlled for optimum air volume.
4. New large diagonal (520 mm) air flow fan. The fan has been designed to reduce air turbulence and increase efficiency. As fan diameter has been increased to 520 mm, the air volume has been increased by 12% whilst maintaining a low sound level.
5. High-efficiency heat exchanger. The heat exchanger size and the copper tube sizes in the heat exchanger have been redesigned to increase efficiency.



Excellent SEER and SCOP values

Panasonic have a extremely high SEER and SCOP values following the SBEM method (some other manufacturers may use another non official calculation method). Developed by BRE, SBEM (Simplified Building Energy Model) is the basis of non-domestic building energy calculations. Based on the National calculation method (NCM), it is used to determine compliance with Part L of the Building Regulations and is also used to provide Energy Performance Certification.

Non-Domestic Building Services Compliance Guide provides information on various aspects of the calculation method, including those of Heat Pumps (Section 3), and Comfort Cooling (Section 9).

SCOP - Seasonal Coefficient of Performance

Part Load COP	25%	50%	75%	100%
Ambient conditions	15°C	7°C	1°C	-5°C
Weighting factor	0,20 (a)	0,36 (b)	0,32 (c)	0,12 (d)

UK winter -5°C DB (outdoor temperature), 20°C WB (indoor temperature)

SEER - Seasonal Energy Efficiency Rating

Part Load COP	25%	50%	75%	100%
Ambient conditions	20°C	25°C	30°C	35°C
Weighting factor	0,20 (a)	0,36 (b)	0,32 (c)	0,12 (d)

UK summer 21°C DB (outdoor temperature), 16°C WB (indoor temperature)

ESEER calculation corresponds with below conditions and power input of indoor units is not included.

- Indoor temperature: 27°C DB / 19°C WB

- Outdoor temperature conditions

Part load ratio	25%	50%	75%	100%
Outdoor air temperature (°C DB)	20	25	30	35
Weighting coefficients	0,23	0,41	0,33	0,03

- Formula : $0,23 \times \text{EER}_{25\%} + 0,41 \times \text{EER}_{50\%} + 0,33 \times \text{EER}_{75\%} + 0,03 \times \text{EER}_{100\%}$.

Compact & Flexible-design

The slim and lightweight design means the PACi outdoor unit can be installed in a number of compact situations.

As the unit only weighs 98 kg, it is easy to carry and easy to install.

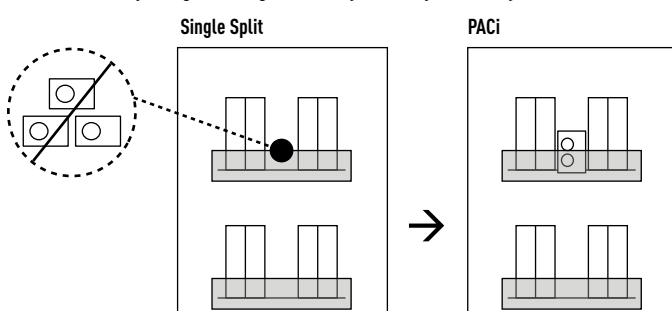

Increased Piping Length for Greater Design Flexibility

Adaptable to various building types and sizes.

Maximum piping length: 75m (10,0, 12,5, 14,0kW). 50m (6,0, 7,1kW).

Maximum total length: 75 m

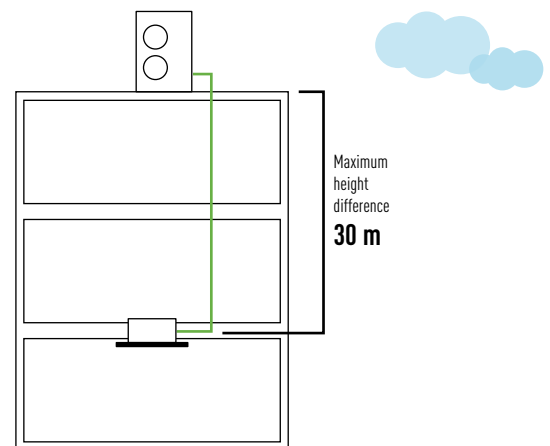

* 15m if the outdoor unit is below the indoor unit.

Demand Response Compliant (CZ-CAPDC3)

This optional part allows demand control of the outdoor unit.

Several level of settings are available:

- Level-1, 2, 3 : 75 / 50 / 0 %
- Level-1, 2 can be set in 40 - 100% (40, 45, 50...95, 100: each 5%)

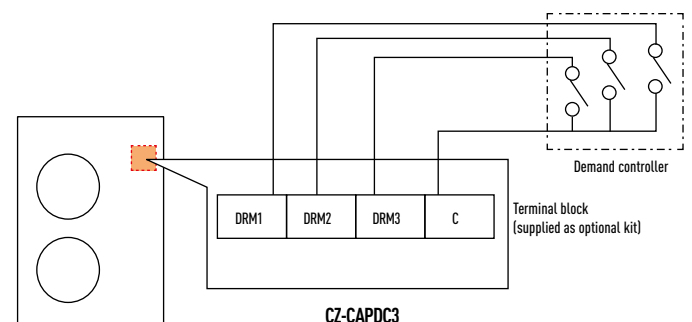

Demand control terminal is available to control 0-50-75% of capacities.

- HIGH ENERGY EFFICIENCY
- 24/7 OPERATION



Solutions for server rooms

High efficiency products for 24/7 applications

Panasonic has developed a complete range of solutions for server rooms which efficiently protect your servers, keeping them at an appropriate temperature even when the outdoor temperature is below -20°C.

SEASONAL EFFICIENCY
SEER – SCOP

A++ A+



SEASONAL EFFICIENCY
SEER – SCOP

A++



Key points

- From 2,5 kW to 5 kW with PKEA units
- From 5 kW to 25 kW with PACi units
- Backup function
- Redundancy function
- Alternative run function
- Error information by dry contact
- Operation even at -20°C outdoor temperature
- Excellent performance with excellent SEER
- Product design for 24/7 operation

High efficiency all the year

On 24/7 operation, the performance of the air conditioning is a key factor. When the efficiency is high, the return on investment of such units is quickly reached.

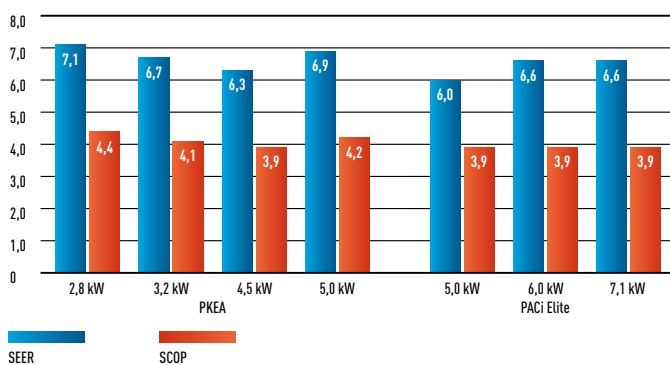

High durability for 24/7 operation

Indoor Fan. Cross-Flow-Fan

- High durability rolling bearings, large size (φ105mm) fan
- High efficiency blade
- Random pitch blade (low sound)

Compressor

DC2P Panasonic original compressor, with high efficiency and reliability.

Why is the Panasonic R2 Rotary Compressor so efficient?

1. High Efficiency Motor The premium silicon steel motor meets industry efficiency requirements.
2. Improved Lubrication of High Volume Oil Pump The extended, high volume oil pump in conjunction with a larger capacity oil reservoir provides superior lubrication.
3. Accumulator has Larger Refrigerant Capacity The larger accumulator accommodates generous refrigerant amounts needed in longer line length installations.

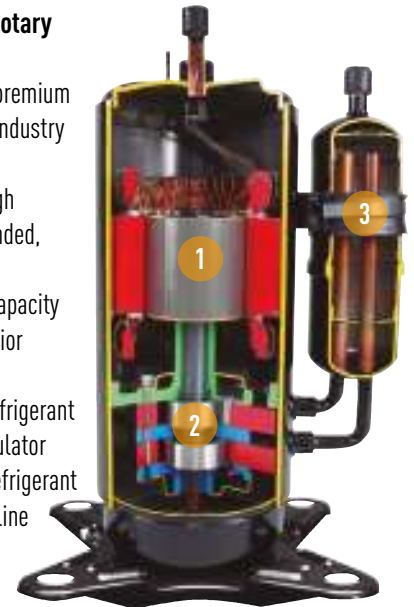

Interfaces to run 2 (for PKEA) or up to 3 (for PACi) units on Backup and alternative run

PAW-SERVER-PKEA for PKEA

The PAW-SERVER-PKEA server room interface manages redundancy and backup of two PKEA units with two different selectable modes:

- Plug and play by embedded redundancy and backup algorithm (no external signal needed. Further details please refer to operation manual)
- External (third party PLC) redundancy and backup management by dry contact

All settings are possible without the need for a computer connection. A special Energy Saving Mode is selectable by deep switch (available only in plug and play mode). The level of remote control input prohibition can be set when external management is by dry contact.

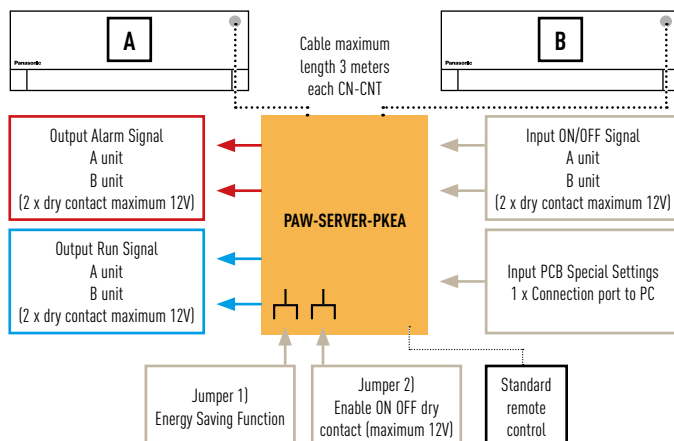

PAW-PACR3 for PACi and ECOi Range

PAW-PACR3, in combination with one PAW-T10V on each indoor unit, allows the redundant operation of 2 (or 3) PAC-i or VRF indoor units.

All units will be operated by programmable turns in order to achieve the same operating time (example turn every 8 hours with 24 hours).

If the room temperature exceeds a freely set value, the 2nd (or 3rd) unit will be switched ON and an alarm will be activated.

In combination with 1x PAW-T10V on each indoor unit, 2 or 3 PACi of ECOi can be programmed to run redundant.

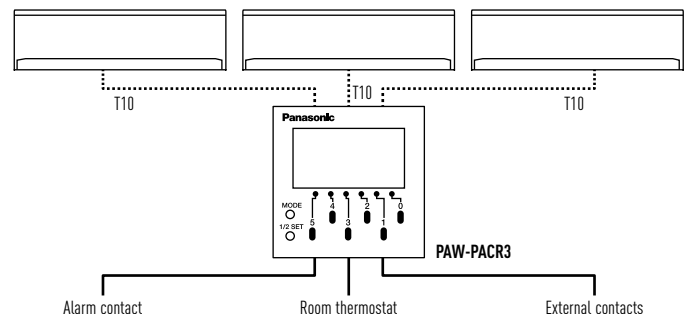

Display and Settings:

- Possible to select next unit manually
- Possible to reset operation
- LED display shows operation status of the 2 or 3 units
- Operation status output
- Alarm LED and alarm output
- Temperature limit can be set
- Temperature hysteresis can be set
- Room temperature is displayed
- Time counter displayed

CZ-CAPRA1

New Domestic with CZ-CNT port integration to PACi and ECOi (available in June 2016).





PACi Standard and Elite: indoor units

4 Way 90x90 Cassette. Wide & Comfortable Airflow

This proprietary design provides a wide and very comfortable airflow. The cassette's wide-angle discharge outlets and flaps are larger in the middle, featuring a shape that was selected based on geometrics and testing of actual prototype units. Air coming out of the center of the discharge outlets travels farther. From the sides of each outlet, where the openings are larger, airflow spreads out to reach the corners of the room. Air is discharged across a wide area from the four sides of the unit. The curves on the room temperature distribution graph expand gently out through 360° in a circle centered on the indoor unit.

Higher efficiency split fin.

Improved heat-transfer coefficient due to adoption of high efficiently grooved heat exchanger tube.

High-efficient & Silent Turbo Fan.

The newly developed larger fan chassis and optimised design of the airflow path has resulted in increased air volume and quieter performance.

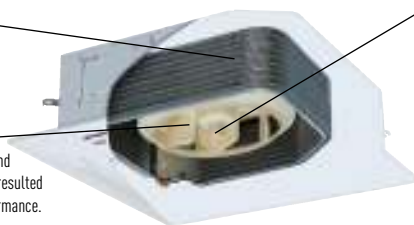

New DC-Fan motor.

Optimum airflow is achieved by a new DC-Fan motor with independent control.

Individual flap control.

Flexible Air flow direction control by individual flap control is possible. 4 Flaps can be controlled individually by setting on wired timer remote controller. It can make more flexible Airflow control to be matched to several demands in a room.

360° Airflow for improved comfort

By redesigning the air-outlet and flap, Soft & 3D airflow circulates whole space and provides even temperature distribution in the room.

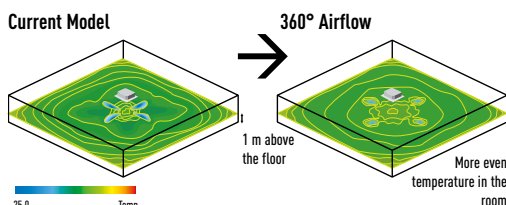

Simulated condition: Floor area: 225 m². Ceiling height: 3 m, Unit 12.5 kW type.

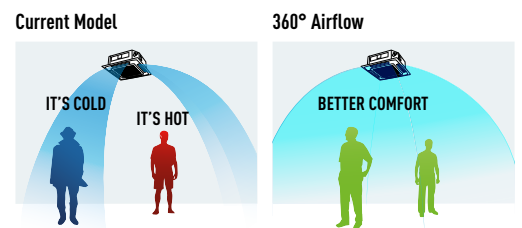

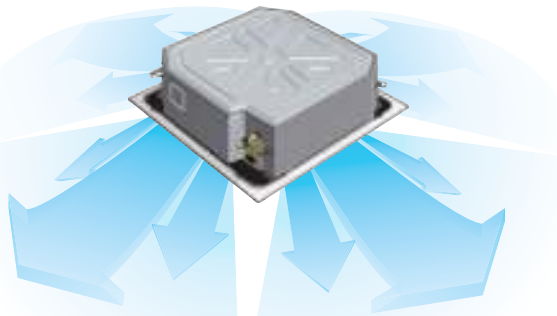

Ample airflow: 36 m³/min
Industry's highest in the 140 PU class.

Flexible 3D air-flow control

Comfort air flow control & proper energy use. Flexible Air flow direction control by individual flap control:

- 4 Flaps can be controlled individually (by standard wired remote controller*).
- Versatile air flow control to cover a wide variety of demands.

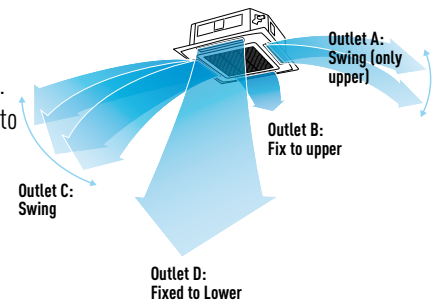

* Pre-setting is required for this function at System Test-run procedure.

High-Ceiling Installation (Up to 5 m for 100 PU and higher models)

The units can be installed in rooms with high ceilings, where they provide ample floor-level heating in the winter. (See ceiling height guidelines below.)

High Ceiling (Factory settings)

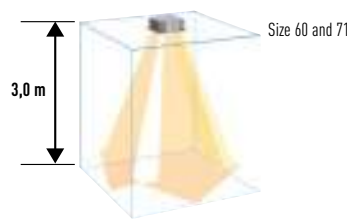

Industry's Top-Class

4-way discharge high ceiling settings²

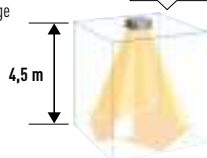

3-way discharge with the optional air-blocking materials

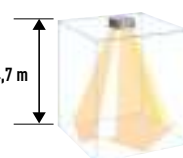

2-way discharge with the optional air-blocking materials

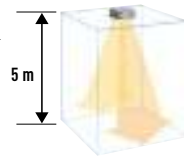

Ceiling height guidelines

Settings ¹	4 - way discharge		3 - way discharge (optional air - blocking materials)		2 - way discharge (optional air - blocking materials) ²
	Factory settings ¹	High ceiling setting ¹	High ceiling setting ²	High ceiling setting ²	High ceiling setting ²
Indoor unit: 60PU-71PU	3,0	3,3	3,6	3,8	4,2
Indoor unit: 100PU, 125PU, 140PU	3,6	3,9	4,5	4,7	5,0

1) When using the unit in a configuration other than the factory settings, it is necessary to make settings on site to increase airflow. 2) Use air-blocking materials (CZ-CFU2) to completely block two discharge outlets for 2-way airflow.

Easy Maintenance and Cleaning

The flap can be removed easily for washing with water.



Low-Profile 33,5 mm Panel

The square panel integrates seamlessly with the ceiling. Discharge outlets close when the unit is stopped.

One of the industry's thinnest panels



Lighter and Slimmer, Easier Installation

A lightweight unit at 24 kg, the unit is also very slim with a height of only 256 mm, making installation possible even in narrow ceiling voids.

A Drain Height of Approx. 850 mm from the Ceiling Surface

The drain height can be increased by approximately 350 mm over the conventional value by using a high-lift drain pump, and long horizontal piping is possible.

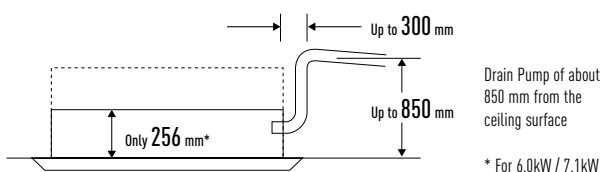

* For 6,0kW / 7,1kW

Dust Prevention

Wide direction air discharge by outlet design.

The Circle Flow Flap and re-designed air-outlet eliminate airflow along recessed parts of the ceiling which reduces contamination. If air flows only along these recessed parts, they will quickly become dirty. The new, improved air outlet design therefore greatly reduces dirt accumulation.

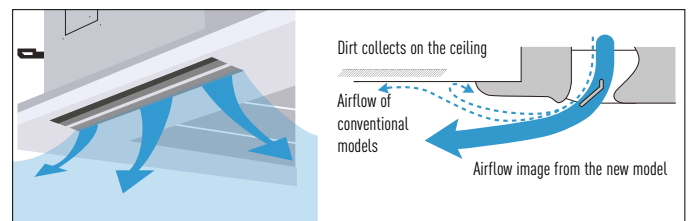



PACi Standard and Elite: indoor units

New 4-Way 60x60 Cassette

Lighter and slimmer, easier installation

Lightweight and very slim which makes installation possible even in narrow ceilings.

A drain height of approximately 850 mm from the ceiling surface

The drain height can be increased by approx. 350 mm over the conventional value by using a high-lift drain pump, and long horizontal piping is possible.

Significant reduction of power consumption by using highly developed DC fan motors with variable speed, special heat exchangers, etc.

Convenient cleaning. The flap can be removed easily for washing.

Wall Mounted

The unit's compact design and flat face ensure discreet installation, even in a small space.

Washable front panel.

The indoor unit's front panel can be easily removed and washed for trouble-free cleaning.

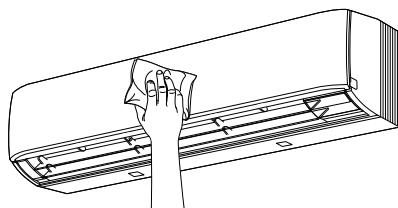

Closed discharge port

When the unit is turned OFF, the flap closes completely to prevent dust getting into the unit and to keep the equipment clean.

Quiet operation

These units are among the quietest in the industry, making them ideal for hotels and hospitals.

Smooth and durable design

The sleek, compact design ensures a discreet installation - even where space is limited.

Piping outlet in three directions

With three options for pipe outlets-rear, right and left - installation is made easy.

Air distribution is altered depending on the operational mode of the unit

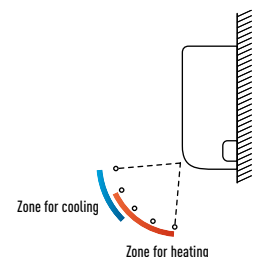

Low Static Pressure Hide Away (PN Type)

Ultra-slim profile: 250 mm height for all models.

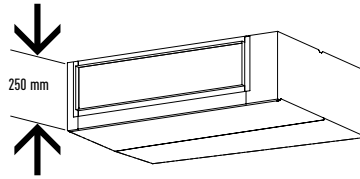

System Example

An inspection port (450 mm x 450 mm or more) is required at the control-box side of the indoor unit body.

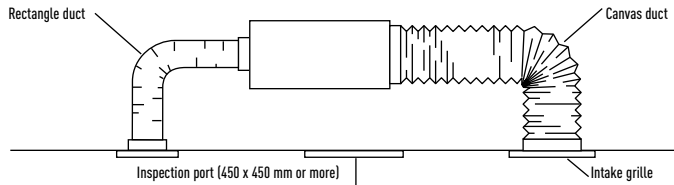

Cold Drafts Reduction at Heating

Accurate DX Coil temperature measurement by E1 and E2 sensor to reduce cold drafts at heating and increasing efficiency and comfort.

Before spec-in, please consult with an authorized Panasonic dealer.

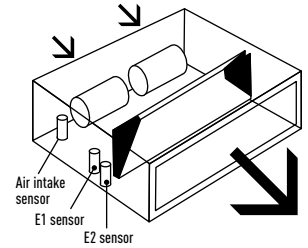

High Static Pressure Hide Away (PF Type)

Standardized height of 290 mm for all models. Height standardization enables easy and uniform installation for models with different capacities.

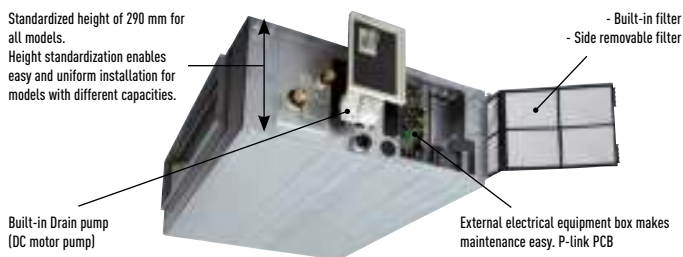

The static pressure outside the unit can be increased up to 150 Pa

Type	60	71	100	125	140
Standard	70 Pa	70 Pa	100 Pa	100 Pa	100 Pa
Maximum available setting	150 Pa	150 Pa	150 Pa	150 Pa	150 Pa

More powerful drain pump

Using a high-lift drain pump, drain piping can be elevated up to 785 mm from the base of the unit.

Air inlet

The unit features air inlet on one side, air outlet on the other side. The air inlet filter can be pulled out from the side of the unit and can be folded. Easy access if through the maintenance opening.

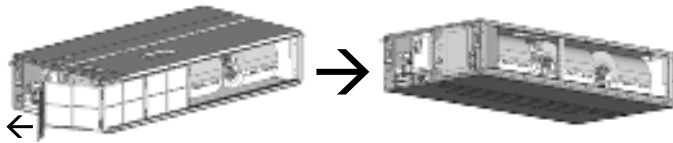

When air inlet duct (field supplied) is connected on suction side, remove the filter, frame and insulation materials on both sides of the unit. Connect the duct on the suction side of the unit by using prepared holes on the unit.

Air outlet site

A rectangular duct flange for the air outlet is fitted as standard. Round outlet flange kits are available as an optional accessory kit.

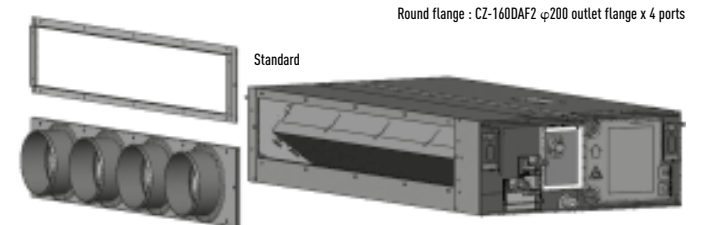

Circle duct flange (option)

N. of exits with diameters	2 x Ø 200	3 x Ø 200	4 x Ø 200
Model Code	CZ-56DAF2 (2 SA outlet)	CZ-90DAF2 (3 SA outlet)	CZ-160DAF2 (4 SA outlet)

Ceiling

Further comfort improvement

The wide air discharge opening expands the air flow to the left and the right. The unpleasant feeling caused when the air flow directly hits the human body is prevented by the "Draft prevention position", which changes the swing width, so that the degree of comfort is increased.

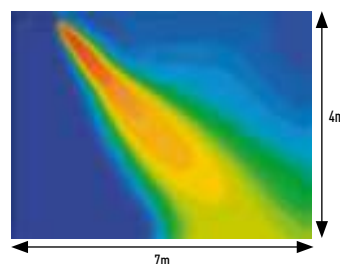

Further comfort improvement with airflow distribution

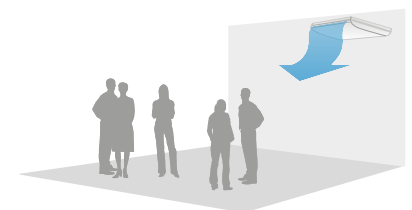

Air distribution is altered depending on the operational mode of the unit

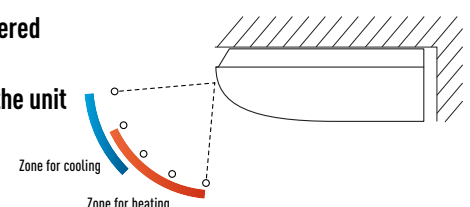

Range of Commercial units

Wall Mounted for professional applications	2,8 kW	3,2 kW	4,5 kW	5,0 kW
Wall Mounted PKEA*	 CS-E9PKEA	 CS-E12PKEA	 CS-E15PKEA	 CS-E18PKEA

* PKEA indoor units are only compatible with PKEA Outdoor Units.

Indoor Units PACi Standard And Elite	3,6 kW	4,5 kW	5,0 kW	6,0 kW
Wall PACi Inverter+	 S-36PK1E5A	 S-45PK1E5A	 S-50PK1E5A	 S-60PK1E5A
4 Way 60x60 Cassette PACi Inverter+	 S-36PY2E5A	 S-45PY2E5A	 S-50PY2E5A	
4 Way 90x90 Cassette PACi Inverter+	 S-36PU1E5A	 S-45PU1E5A	 S-50PU1E5A	 S-60PU1E5A
Low Static Pressure Hide Away PACi Inverter+	 S-36PN1E5A	 S-45PN1E5A	 S-50PN1E5A	 S-60PN1E5A
High Static Pressure Hide Away PACi Inverter+	 S-36PF1E5A	 S-45PF1E5A	 S-50PF1E5A	 S-60PF1E5A
Ceiling PACi Inverter+	 S-36PT2E5A	 S-45PT2E5A	 S-50PT2E5A	 S-60PT2E5A
High Static Pressure Hide Away 20,0 - 25,0 kW PACi Inverter+	NEW			
Air Curtain with DX Coil Jet-Flow				
Air Curtain with DX Coil Standard				

* The indoor units from 3,6 to 5,0 kW are only available only for Twin, Triple and Doble-Twin combinations.

Outdoor Units PACi Standard and Elite			5,0 kW	6,0 kW
PACi Standard				 U-60PEY1E5 ¹
PACi Elite			 U-50PE1E5 ¹	 U-60PE1E5 ¹

¹ Single Phase ² Three Phase

Air Handling Unit	28,0 kW
2 types of AHU Kit: Advanced and Standard. Up to 28 kW	
	PAW-280PAH2 PAW-280PAH2L

(Common use for all outdoor units. Only 1 by 1 connection is allowed.)

7,1 kW	10,0 kW	12,5 kW	14,0 kW	20,0 kW	25,0 kW
 S-71PK1E5A	 S-100PK1E5A (9,5 kW)				
 S-71PU1E5A	 S-100PU1E5A	 S-125PU1E5A	 S-140PU1E5A		
 S-71PN1E5A	 S-100PN1E5A	 S-125PN1E5A	 S-140PN1E5A		
 S-71PF1E5A	 S-100PF1E5A	 S-125PF1E5A	 S-140PF1E5A		
 S-71PT2E5A	 S-100PT2E5A	 S-125PT2E5A	 S-140PT2E5A		
				 S-200PE2E5	 S-250PE2E5
	 PAW-10PAIRC-MJ (9,2 kW)		 PAW-15PAIRC-MJ (17,5 kW)	 PAW-20PAIRC-MJ (23,1 kW)	
	 PAW-10PAIRC-MS (9,2 kW)		 PAW-20PAIRC-MS (17,5 kW)		

7,1 kW	10,0 kW	12,5 kW	14,0 kW	20,0 kW	25,0 kW
 U-71PE1E5 ¹	 U-100PE1E5 ¹ // U-100PE1E8 ^{III}	 U-125PE1E5 ¹ // U-125PE1E8 ^{III}	 U-140PE1E8 ^{III}		
 U-71PE1E5A ¹ // U-71PE1E8A ^{III}	 U-100PE1E5A ¹ // U-100PE1E8A ^{III}	 U-125PE1E5A ¹ // U-125PE1E8A ^{III}	 U-140PE1E5A ¹ // U-140PE1E8A ^{III}	 U-200PE1E8 ^{III}	 U-250PE1E8 ^{III}

WALL MOUNTED PKEA

Complete line-up with high efficiency even at -15°C

This Wall Mounted air conditioner is especially designed for professional applications such as computer rooms where cooling inside the room is necessary even when the outside temperature is low. Furthermore this air conditioner has an automatic changeover system, in order to maintain the inside temperature even when sharp outside temperature changes occur.

			Single Phase			
			2,8 kW	3,2 kW	4,5 kW	5,0 kW
KIT			KIT-E9-PKEA	KIT-E12-PKEA	KIT-E15-PKEA	KIT-E18-PKEA
Cooling capacity	Nominal (Min-Max)	kW	2,50 (0,85 - 3,00)	3,50 (0,85 - 4,00)	4,20 (0,98 - 5,00)	5,00 (0,98 - 6,00)
EER ¹⁾	Nominal (Min - Max)	W/W	4,85 (4,23 - 5,00) A	4,02 (3,57 - 5,00) A	3,50 (3,50 - 3,16) A	3,47 (3,50 - 3,02) A
Cooling capacity at -10°C	Nominal	kW	2,63	3,69	5,04	6,00
EER at -10°C	Nominal	W/W	7,19	5,96	6,01	6,00
Cooling capacity at -20°C	Nominal	kW	2,61	3,66	4,06	5,82
EER at -20°C	Nominal	W/W	6,71	5,56	4,39	5,39
SEER ²⁾	Nominal	W/W	7,1 A++	6,7 A++	6,3 A++	6,9 A++
Pdesign		kW	2,5	3,5	4,2	5,0
Power input cooling	Nominal (Min-Max)	kW	0,515 (0,170 - 0,710)	0,870 (0,170 - 1,120)	1,200 (0,280 - 1,580)	1,440 (0,280 - 1,990)
Annual electricity consumption (cooling) ³⁾		kWh/a	123	183	233	254
Heating capacity	Nominal (Min-Max)	kW	3,40 (0,85 - 5,40)	4,00 (0,85 - 6,60)	5,40 (0,98 - 7,10)	5,80 (0,98 - 8,00)
Heating capacity at -7°C ⁴⁾	Nominal	kW	3,33	4,07	4,10	4,98
COP ⁵⁾	Nominal (Min - Max)	W/W	4,86 (4,12 - 5,15) A	4,35 (3,63 - 5,15) A	3,75 (2,88 - 3,24) A	3,82 (2,88 - 3,11) A
SCOP ⁵⁾	Nominal	W/W	4,4 A+	4,1 A+	3,9 A	4,2 A+
Pdesign at -10 °C		kW	2,8	3,6	3,6	4,4
Power input heating	Nominal (Min-Max)	kW	0,700 (0,165 - 1,310)	0,920 (0,165 - 1,820)	1,440 (0,340 - 2,190)	1,520 (0,340 - 2,570)
Annual electricity consumption (heating) ³⁾		kWh/a	891	1.229	1.292	1.467
Indoor Unit			CS-E9PKEA	CS-E12PKEA	CS-E15PKEA	CS-E18PKEA
Power source		V	230	230	230	230
Recommended fuse		A	16	16	16	16
Connection indoor / outdoor		mm	4 x 1,5	4 x 1,5	4 x 1,5	4 x 2,5
Current (Nominal)	Cooling / Heating	A	2,5 / 3,3	4,0 / 4,2	5,4 / 6,5	6,4 / 6,8
Max. Current		A	7,8	8,4	9,6	11,3
Air Volume	Cooling / Heating	m³/h	798 / 876	816 / 882	846 / 900	1.074 / 1.158
Moisture removal volume		l/h	1,5	2,0	2,4	2,8
Sound pressure level ⁶⁾	Cooling (Hi / Lo / S-Lo)	dB(A)	39 / 26 / 23	42 / 29 / 26	43 / 32 / 29	44 / 37 / 34
	Heating (Hi / Lo / S-Lo)	dB(A)	40 / 27 / 24	42 / 33 / 29	43 / 35 / 29	44 / 37 / 34
Sound power level	Cooling / Heating (Hi)	dB	55 / 56	58 / 58	59 / 59	60 / 60
Dimensions / Net weight	H x W x D	mm / kg	295 x 870 x 255 / 10	295 x 870 x 255 / 10	295 x 870 x 255 / 10	295 x 1.070 x 255 / 13
Outdoor Unit			CU-E9PKEA	CU-E12PKEA	CU-E15PKEA	CU-E18PKEA
Air Volume	Cooling / Heating	m³/h	1.878 / 1.782	1.974 / 1.926	2.052 / 1.980	2.352 / 2.274
Sound pressure level ⁶⁾	Cooling / Heating (Hi)	dB(A)	46 / 47	48 / 50	46 / 46	47 / 47
Sound power level	Cooling / Heating (Hi)	dB	61 / 62	63 / 65	61 / 61	61 / 61
Dimensions ⁷⁾ / Net weight	H x W x D	mm / kg	622 x 824 x 299 / 36	622 x 824 x 299 / 36	695 x 875 x 320 / 45	695 x 875 x 320 / 46
Piping connections	Liquid pipe / Gas pipe	Inch (mm)	1/4 (6,35) / 3/8 (9,52)	1/4 (6,35) / 3/8 (9,52)	1/4 (6,35) / 1/2 (12,70)	1/4 (6,35) / 1/2 (12,70)
Refrigerant loading	R410A	kg	1.100	1.100	1,060	1,240
Piping length range / Elevation difference (in/out) ⁸⁾		m	3 - 15 / 5	3 - 15 / 5	3 - 15 / 5	3 - 20 / 15
Pipe length for additional gas / Additional gas amount		m / g/m	7,5 / 20	7,5 / 20	7,5 / 20	7,5 / 20
Operating range	Cooling Min / Max	°C	-15 / +43	-15 / +43	-15 / +43	-15 / +43
	Heating Min / Max	°C	-15 / +24	-15 / +24	-15 / +24	-15 / +24

Rating Conditions: Cooling Indoor 27°C DB / 19°C WB. Cooling Outdoor 35°C DB / 24°C WB. Heating Indoor 20°C DB. Heating Outdoor 7°C DB / 6°C WB. (DB: Dry Bulb; WB: Wet Bulb).

Rating Conditions for cooling capacity at low temperature: Cooling Indoor 27°C DB / 19°C WB. Cooling Outdoor 0°C DB / -10°C WB.

1) EER and COP, Energy Saving Classification, is at 220 / 240 V (380 / 415 V) only in accordance with EU directive 2002/31/EC. 2) SEER is calculated in base Eurovent IPLV for SBEM for U1 indoor unit SEER=a(EER25)+b(EER50)+c(EER75)+d(EER100) where EER25, EER50, EER75 and EER100 are the EER measured value at 25%, 50%, 75% and 100% part load for temperatures 20, 25, 30 and 35°C DB, respectively. a, b, c and d are values assigned for an office type. These values are given as a=0,2, b=0,36, c=0,32 and d=0,03. The internal temperatures are taken at 27°C DB and 19°C WB. 3) The annual consumption (ErP) is calculated by formula determined by ErP regulation. 4) Heating capacity is calculated including defrost factor correction. 5) SCOP is calculated in base Eurovent IPLV for SBEM with U1 indoor unit including defrost correction factor. 6) The Sound pressure level of the units shows the value measured of a position 1 meter in front of the main body and 1.5 m from the ground. The sound pressure is measured in accordance with Eurovent 6/C/006-97 specification. 7) Add 70 mm for piping port. 8) When installing the outdoor unit at a higher position than the indoor unit. // Recommended fuse for the indoor 3A. // Specifications subject to change without notice.

For detailed information about ErP, please visit our websites www.aircon.panasonic.eu or www.ptc.panasonic.eu



SEER and SCOP: For KIT-E9-PKEA. INTERNET CONTROL: Optional.

- SERVER ROOM SOLUTION WITH THE HIGHEST EFFICIENCY OF THE MARKET
- 24/7 OPERATION



Included on the kit.
Timer remote controller

Technical focus

- This units can be installed on R22 pipings
- Designed for 24h/7d a week operation
- Highly efficient even at -15°C
- High durability rolling bearings
- Additional piping sensors to prevent freezing

Features

Outdoor

- Cooling even when ambient temperature is as low as -15°C
- Electronic expansion valve (accurate sub-cooling and adjustable refrigerant flow)
- Outdoor DC fan motor to provide flexible air-flow to ensure optimum condensation pressure (works on outdoor pipe temperature sensor)

Interface option to manage server room operation

The PAW-SERVER-PKEA server room interface manages redundancy and backup of two PKEA units with two different selectable modes:

- Plug and play by embedded redundancy and backup algorithm (no external signal needed. Further details please refer to operation manual)
- External (third party PLC) redundancy and backup management by dry contact

All settings are possible without the need for a computer connection.

A special Energy Saving Mode is selectable by deep switch (available only in plug and play mode). The level of remote control input prohibition can be set when external management is by dry contact.

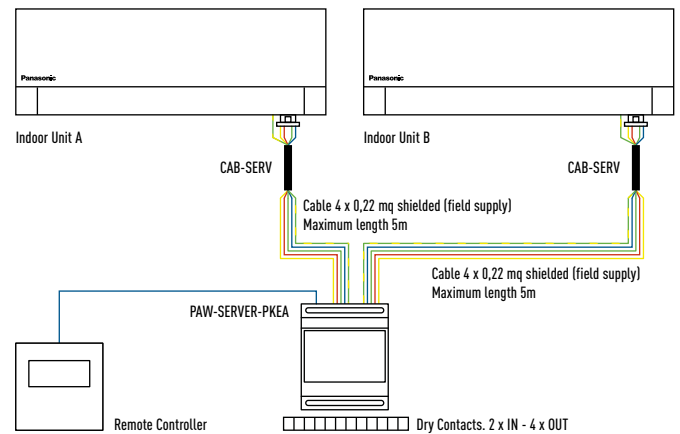

Main Features

- Cascade management
- Back Up system
- Overheating prevention
- ECO function
- BMS management available

Only available

- CS.EXXPKEA
- CS.EXXQKE / PKE / NKE

Accessories



PAW-GRDSTD40
Outdoor elevation platform 400 x 900 x 400 mm.



PAW-WTRAY
Tray for condenser water compatible with base ground support



PAW-GRDBSE20
Outdoor base ground support for noise and vibration absorption (600 x 95 x 130 mm, 500 kg)



PAW-SERVER-PKEA
PCB for installation in server rooms with security.

CZ-CAPRA1
CZ-ENI port integration to PACI and EODI (available in June 2016).



CU-E9PKEA
CU-E12PKEA



CU-E15PKEA
CU-E18PKEA

WALL MOUNTED
PACi STANDARD AND ELITE
INVERTER+

New Wall Mounted PACi. The extension of the range to include a 10 kW unit allows for many more applications such as studios, gyms, high ceiling areas and even computer server rooms.

Technical focus

- 10,0 kW capacity unit
- Flat face design for modern appearance
- Compact design offers over 15% reduction in overall size
- Washable front panel
- DC FAN for better efficiency and control
- Three directional piping outlet
- Easy connection and control of external fan or ERV using the connector PAW-FDC on the indoor unit PCB. The external device can be control by the remote control of the Panasonic indoor unit

Standard

		Single Phase		Three Phase	
		6,0 kW	7,1 kW	10,0 kW	10,0 kW
KIT		KIT-60PKY1E5A	KIT-71PKY1E5A	KIT-100PKY1E5A	KIT-100PKY1E8A
Indoor		S-60PK1E5A	S-71PK1E5A	S-100PK1E5A	S-100PK1E5A
Outdoor		U-60PEY1E5	U-71PEY1E5	U-100PEY1E5	U-100PEY1E8
Timer remote controller		CZ-RTC4	CZ-RTC4	CZ-RTC4	CZ-RTC4
Cooling capacity	Nominal (Min - Max)	kW	6,0 (2,0 - 7,0)	7,1 (2,0 - 7,7)	9,0 (2,7 - 9,7)
EER ¹⁾	Nominal (Min - Max)	W/W	3,23 (6,15 - 2,55) A	2,90 (6,15 - 2,57) C	2,67 (5,09 - 2,55) D
SEER ²⁾		W/W	5,4 A	5,1 A	5,7 A+
Pdesign		kW	6,0	7,1	9,0
Power input cooling	Nominal (Min - Max)	kW	1,860 (0,325 - 2,750)	2,450 (0,325 - 3,000)	3,370 (0,530 - 3,800)
Annual energy consumption (ErP) ³⁾		kWh/a	389	487	543
Heating capacity	Nominal (Min - Max)	kW	6,0 (1,8 - 7,0)	7,1 (1,8 - 8,1)	9,0 (2,1 - 10,5)
Heating capacity at -7°C ⁴⁾	Nominal	kW	4,99	5,08	9,97
Heating capacity at -15°C ⁴⁾	Nominal	kW	4,20	4,37	8,43
COP ¹⁾	Nominal (Min - Max)	W/W	4,00 (6,55 - 3,18) A	3,74 (6,55 - 3,18) A	3,70 (5,12 - 3,50) A
SCOP ⁵⁾		W/W	3,9 A	3,9 A	3,8 A
Pdesign at -10°C		kW	6,0	6,0	9,0
Power input heating	Nominal (Min - Max)	kW	1,500 (0,275 - 2,200)	1,900 (0,275 - 2,550)	2,430 (0,410 - 3,000)
Annual energy consumption (ErP) ³⁾		kWh/a	2.154	2.154	3.316
Indoor unit					
Air volume	Cooling (Hi / Med / Lo)	m³/h	1.080 / 870 / 690	1.080 / 870 / 690	1.140 / 990 / 780
	Heating (Hi / Med / Lo)	m³/h	1.080 / 870 / 690	1.080 / 870 / 690	1.140 / 990 / 780
Moisture removal volume		l/h	3,4	4,2	5,4
Sound pressure level ⁶⁾	Cooling (Hi / Med / Lo)	dB(A)	47 / 44 / 40	47 / 44 / 40	49 / 45 / 41
	Heating (Hi / Med / Lo)	dB(A)	47 / 44 / 40	47 / 44 / 40	49 / 45 / 41
Sound power level	Cooling (Hi)	dB	64	64	65
	Heating (Hi)	dB	64	64	65
Dimensions / Net weight	H x W x D	mm / kg	300 x 1.065 x 230 / 14,5	300 x 1.065 x 230 / 14,5	300 x 1.065 x 230 / 14,5
Outdoor unit					
Power source		V	220 / 230 / 240	220 / 230 / 240	220 / 230 / 240
Recommended fuse		A	20	20	25
Connection		mm²	2,5	2,5	4,0
Current	Cooling	A	8,80 / 8,50 / 8,25	11,7 / 11,3 / 10,9	16,0 / 15,3 / 14,6
	Heating	A	7,05 / 6,80 / 6,60	9,00 / 8,70 / 8,40	11,2 / 10,8 / 10,4
Air volume	Cooling / Heating	m³/h	1.800 / 2.100	2.340 / 2.340	4.560 / 4.020
Sound pressure level	Cooling / Heating (Hi)	dB(A)	46 / 50	50 / 52	54 / 54
Sound power level	Cooling / Heating (Hi)	dB	65 / 69	70 / 70	70 / 70
Dimensions / Net weight	H x W x D	mm / kg	569 x 790 x 285 / 42	569 x 790 x 285 / 42	996 x 940 x 340 / 73
Piping connections	Liquid pipe	Inch (mm)	3/8 (9,52)	3/8 (9,52)	3/8 (9,52)
	Gas pipe	Inch (mm)	5/8 (15,88)	5/8 (15,88)	5/8 (15,88)
Refrigerant loading	R410A	kg	1,7	1,7	2,60
Piping length / Elevation difference (in/out) ⁷⁾		m	5 - 50 / 30	5 - 50 / 30	5 - 50 / 30
Pipe length for additional gas / Additional gas amount		m / g/m	20 / 40	20 / 40	30 / 50
Operating range	Cooling Min / Max	°C	-10 / +43	-10 / +43	-10 / +43
	Heating Min / Max	°C	-15 / +24	-15 / +24	-15 / +24

Rating Conditions: Cooling Indoor 27°C DB / 19°C WB. Cooling Outdoor 35°C DB / 24°C WB. Heating Indoor 20°C DB. Heating Outdoor 7°C DB / 4°C WB. (DB: Dry Bulb; WB: Wet Bulb). // Specifications subject to change without notice.
 1) EER and COP, Energy Saving Classification, is at 220 / 240 V (380 / 415 V) only in accordance with EU directive 2002/31/EC. 2) SEER is calculated in base Eurovent IPLV for SBEM for U1 indoor unit SEER=a(EER25)+b(EER50)+c(EER75)+d(EER100) where EER25, EER50, EER75 and EER100 are the EER measured value at 25%, 50%, 75% and 100% part load for temperatures 20, 25, 30 and 35°C DB, respectively. a, b, c and d are values assigned for an office type. These values are given as a=0,2, b=0,36, c=0,32 and d=0,03. The internal temperatures are taken at 27°C DB and 19°C WB. 3) The annual consumption (ErP) is calculated by formula determined by ErP regulation. 4) Heating capacity is calculated including defrost factor correction. 5) SCOP is calculated in base Eurovent IPLV for SBEM with U1 indoor unit including defrost correction factor. 6) The Sound pressure level of the units shows the value measured of a position 1 meter in front of the main body and 1,5 m from the ground. The sound pressure is measured in accordance with Eurovent 6/C/006-97 specification. 7) When installing the outdoor unit at a higher position than the indoor unit. // Recommended fuse for the indoor 3A. // For detailed information about ErP, please visit our websites www.aircon.panasonic.eu or www.ptc.panasonic.eu

Standard

Elite

--	--	--	--	--	--	--	--	--	--	--	--	--	--	--

SEER and SCOP: For KIT-60PKY1E5A.

SEER and SCOP: For KIT-60PKY1E5A and KIT-71PKY1E5A.

INTERNET CONTROL: Optional.

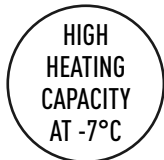

Optional Controller
Wired remote controller
CZ-RTC5



Optional Controller
Timer remote controller
CZ-RTC4



Optional Controller
Wireless remote controller
CZ-RWSK2



Optional Controller
Simplified remote controller
CZ-RE2C2

Compatible with all Panasonic connectivity solutions. For detailed information go to the Control Systems section.

Elite

			Single Phase				Three Phase	
			5,0 kW	6,0 kW	7,1 kW	10,0 kW	7,1 kW	10,0 kW
			KIT-50PK1E5A	KIT-60PK1E5A	KIT-71PK1E5A	KIT-100PK1E5A	KIT-71PK1E8A	KIT-100PK1E8A
			S-50PK1E5A	S-60PK1E5A	S-71PK1E5A	S-100PK1E5A	S-71PK1E8A	S-100PK1E8A
			U-50PE1E5	U-60PE1E5A	U-71PE1E5A	U-100PE1E5A	U-71PE1E8A	U-100PE1E8A
			CZ-RTC4	CZ-RTC4	CZ-RTC4	CZ-RTC4	CZ-RTC4	CZ-RTC4
Cooling capacity	Nominal (Min - Max)	kW	5,0 (1,5 - 5,6)	6,0 (2,5 - 7,1)	7,1 (2,5 - 8,0)	9,5 (3,3 - 10,5)	7,1 (3,2 - 8,0)	9,5 (3,3 - 10,5)
EER ¹⁾	Nominal (Min - Max)	W/W	3,21 (5,77 - 2,49) A	3,85 (5,56 - 3,55) A	3,40 (5,56 - 3,02) A	3,25(3,93 - 3,09)A	3,40 (5,71 - 3,02) A	3,25(3,93 - 3,09)A
SEER ²⁾		W/W	6,0 A+	6,6 A++	6,6 A++	6,2 A++	6,1 A++	6,0 A+
Pdesign		kW	5,0	6,0	7,1	9,5	7,1	9,5
Power input cooling	Nominal (Min - Max)	kW	1,560 (0,260 - 2,250)	1,560 (0,450 - 2,000)	2,090 (0,450 - 2,650)	2,920 (0,840 - 3,400)	2,090 (0,560 - 2,650)	2,920 (0,840 - 3,400)
Annual energy consumption (ErP) ³⁾		kWh/a	292	318	376	536	407	554
Heating capacity	Nominal (Min - Max)	kW	5,6 (1,5 - 6,5)	7,0 (2,0 - 8,0)	8,0 (2,0 - 9,0)	9,5 (4,1 - 11,5)	8,0 (2,8 - 9,0)	9,5 (4,1 - 11,5)
Heating capacity at -7°C ⁴⁾	Nominal	kW	4,20	6,69	7,52	12,04	7,52	12,04
Heating capacity at -15°C ⁴⁾	Nominal	kW	3,58	6,56	7,65	11,20	7,65	11,20
COP ¹⁾	Nominal (Min - Max)	W/W	3,73 (6,82 - 2,65) A	3,85 (5,00 - 3,23) A	3,76 (5,00 - 3,10) A	3,85 (4,56 - 3,43) A	3,76 (5,60 - 3,10) A	3,85 (4,56 - 3,43) A
SCOP ⁵⁾		W/W	3,9 A	3,9 A	3,9 A	3,8 A	3,8 A	3,8 A
Pdesign at -10°C		kW	4,0	6,0	7,1	9,5	7,1	9,5
Power input heating	Nominal (Min - Max)	kW	1,500 (0,220 - 2,450)	1,820 (0,400 - 2,480)	2,130 (0,400 - 2,900)	2,470 (0,900 - 3,350)	2,130 (0,500 - 2,900)	2,470 (0,900 - 3,350)
Annual energy consumption (ErP) ³⁾		kWh/a	1.436	2.154	2.548	3.500	2.616	3.500
Indoor unit								
Air volume	Cooling (Hi / Med / Lo)	m³/h	840 / 720 / 630	1.080 / 870 / 690	1.080 / 870 / 690	1.140 / 990 / 780	1.080 / 870 / 690	1.140 / 990 / 780
	Heating (Hi / Med / Lo)	m³/h	840 / 720 / 630	1.080 / 870 / 690	1.080 / 870 / 690	1.140 / 990 / 780	1.080 / 870 / 690	1.140 / 990 / 780
Moisture removal volume		l/h	2,8	3,4	4,2	5,7	4,2	5,7
Sound pressure level ⁶⁾	Cooling (Hi / Med / Lo)	dB(A)	40 / 36 / 32	47 / 44 / 40	47 / 44 / 40	49/45/41	47 / 44 / 40	49/45/41
	Heating (Hi / Med / Lo)	dB(A)	40 / 36 / 32	47 / 44 / 40	47 / 44 / 40	49/45/41	47 / 44 / 40	49/45/41
Sound power level	Cooling (Hi)	dB	57	64	64	65	64	65
	Heating (Hi)	dB	57	64	64	65	64	65
Dimensions / Net weight	H x W x D	mm / kg	300 x 1.065 x 230 / 13,0	300 x 1.065 x 230 / 14,5	300 x 1.065 x 230 / 14,5	300 x 1065 x 230 / 14,5	300 x 1.065 x 230 / 14,5	300 x 1065 x 230 / 14,5
Outdoor unit								
Power source		V	220 / 230 / 240	220 / 230 / 240	220 / 230 / 240	220 / 230 / 240	380 / 400 / 415	380 / 400 / 415
Recommended fuse		A	16	20	20	25	16	16
Connection		mm²	2,5	2,5	2,5	4	2,5	2,5
Current	Cooling	A	7,25 / 7,00 / 6,80	7,45 / 7,15 / 6,95	9,75 / 9,40 / 9,10	13,4 / 12,9 / 12,4	3,25 / 3,15 / 3,05	4,60 / 4,40 / 4,30
	Heating	A	6,95 / 6,75 / 6,50	8,45 / 8,15 / 7,90	9,85 / 9,50 / 9,20	11,3 / 10,9 / 10,6	3,30 / 3,20 / 3,10	3,85 / 3,70 / 3,60
Air volume	Cooling / Heating	m³/h	1.800 / 2.100	3.600 / 3.600	3.600 / 3.600	6.600 / 5.700	3.600 / 3.600	6.600 / 5.700
Sound pressure level	Cooling / Heating (Hi)	dB(A)	46 / 50	48 / 50	48 / 50	52 / 52	48 / 50	52 / 52
Sound power level	Cooling / Heating (Hi)	dB	65 / 69	65 / 67	65 / 67	69 / 69	65 / 67	69 / 69
Dimensions / Net weight	H x W x D	mm / kg	569 x 790 x 285 / 42	996 x 940 x 340 / 68	996 x 940 x 340 / 69	1.416 x 940 x 340 / 98	996 x 940 x 340 / 71	1.416 x 940 x 340 / 98
Piping connections	Liquid pipe	Inch (mm)	1/4 (6,35)	3/8 (9,52)	3/8 (9,52)	3/8 (9,52)	3/8 (9,52)	3/8 (9,52)
	Gas pipe	Inch (mm)	1/2 (12,7)	5/8 (15,88)	5/8 (15,88)	5/8 (15,88)	5/8 (15,88)	5/8 (15,88)
Refrigerant loading	R410A	kg	1,65	2	2,35	3,4	2,35	3,4
Piping length / Elevation difference (in/out) ⁷⁾		m	5 - 40 / 30	5 - 50 / 30	5 - 50 / 30	5 - 75 / 30	5 - 50 / 30	5 - 75 / 30
Pipe length for additional gas / Additional gas amount		m / g/m	30 / 20	30 / 50	30 / 50	30 / 50	30 / 50	30 / 50
Operating range	Cooling Min / Max	°C	-15 / +46	-15 / +46	-15 / +46	-15 / +46	-15 / +46	-15 / +46
	Heating Min / Max	°C	-20 / +24	-20 / +24	-20 / +24	-20 / +24	-20 / +24	-20 / +24

Rating Conditions: Cooling Indoor 27°C DB / 19°C WB. Cooling Outdoor 35°C DB / 24°C WB. Heating Indoor 20°C DB. Heating Outdoor 7°C DB / 6°C WB. (DB: Dry Bulb; WB: Wet Bulb). // Specifications subject to change without notice.

1) EER and COP, Energy Saving Classification, is at 220 / 240 V (380 / 415 V) only in accordance with EU directive 2002/31/EC. 2) SEER is calculated in base Eurovent IPLV for SBEM for U1 indoor unit SEER=a(EER25)+b(EER50)+c(EER75)+d(EER100) where EER25, EER50, EER75 and EER100 are the EER measured value at 25%, 50%, 75% and 100% part load for temperatures 20, 25, 30 and 35°C DB, respectively. a, b, c and d are values assigned for an office type. These values are given as a=0,2, b=0,36, c=0,32 and d=0,03. The internal temperatures are taken at 27°C DB and 19°C WB. 3) The annual consumption (ErP) is calculated by formula determined by ErP regulation. 4) Heating capacity is calculated including defrost factor correction. 5) SCOP is calculated in base Eurovent IPLV for SBEM with U1 indoor unit including defrost correction factor. 6) The Sound pressure level of the units shows the value measured of a position 1 meter in front of the main body and 1,5 m from the ground. The sound pressure is measured in accordance with Eurovent 6/C/006-97 specification. 7) When installing the outdoor unit at a higher position than the indoor unit. // Recommended fuse for the indoor 3A. // For detailed information about ErP, please visit our websites www.aircon.panasonic.eu or www.ptc.panasonic.eu

Accessories



PAN-GRDSTD40
Outdoor elevation platform 400 x 900 x 400 mm.



PAN-WTRAY
Tray for condenser water compatible with base ground support



PAN-GRDSE20
Outdoor base ground support for noise and vibration absorption (400 x 95 x 130 mm, 500 kg)



PAN-WPH7: Wind protection shield for U-50PE1E5, PAN-WPH6: Wind protection shield for U-200PE1E8, U-250PE1E8, U-250PE1E8, PAN-WPH7: Wind protection shield for U-60PE1E5, U-71PE1E5/R, U-100PE1E5/R, U-125PE1E5/R, PAN-WPH10: Wind protection shield for U-100PE1E5/R, U-125PE1E5/R, U-140PE1E5/R, U-140PE1E8.



PAN-PCR3
Interfaces to run 3 units on Backup and alternative run.



U-60PE1E5



U-50PE1E5

U-100PE1E5
U-100PE1E8
U-60PE1E8A
U-100PE1E8A
U-71PE1E8A
U-100PE1E8A

4 WAY 60x60 CASSETTE PACi STANDARD AND ELITE INVERTER+

Small and powerful, ideal for offices and restaurants. Only for Twin, Triple and Double-twin combinations.

Technical focus

- Fresh air knock out
- Multidirectional air flow
- Integrated drain pump gives 850 mm lift
- 3 speed centrifugal fan
- DC FAN for better efficiency and control
- Easy connection and control of external fan or ERV using the connector PAW-FDC on the indoor unit PCB. The external device can be control by the remote control of the Panasonic indoor unit

Standard

			3,6 kW	4,5 kW	5,0 kW
Indoor			S-36PY2E5A ¹⁾ *	S-45PY2E5A ¹⁾ *	S-50PY2E5A*
Panel			CZ-KPY3A / CZ-KPY3B	CZ-KPY3A / CZ-KPY3B	CZ-KPY3A / CZ-KPY3B
Cooling capacity	Nominal	kW	3,6	4,5	5,0
Heating capacity	Nominal	kW	4,2	5,2	5,6
Air volume	Cool/Heat	m ³ /h	582 / 594	600 / 618	666 / 666
Moisture removal volume		l/h	2,1	2,5	2,8
Sound pressure level ^{d)}	Cooling (Hi / Med / Lo)	dB(A)	36 / 32 / 26	38 / 34 / 28	40 / 37 / 33
	Heating (Hi / Med / Lo)	dB(A)	36 / 32 / 26	38 / 34 / 28	40 / 37 / 33
Sound power level	Cooling (Hi)	dB	51 / 47 / 41	53 / 49 / 43	55 / 52 / 48
	Heating (Hi)	dB	51 / 47 / 41	53 / 49 / 43	55 / 52 / 48
Dimensions (H x W x D)	Indoor	mm	288 x 583 x 583	288 x 583 x 583	288 x 583 x 583
	Panel CZ-KPY3A / CZ-KPY3B	mm	31 x 700 x 700 / 31 x 625 x 625	31 x 700 x 700 / 31 x 625 x 625	31 x 700 x 700 / 31 x 625 x 625
Net weight	Indoor (Panel)	kg	18 (2,4)	18 (2,4)	18 (2,4)

Rating Conditions: Cooling Indoor 27°C DB / 19°C WB. Cooling Outdoor 35°C DB / 24°C WB. Heating Indoor 20°C DB. Heating Outdoor 7°C DB / 6°C WB. (DB: Dry Bulb; WB: Wet Bulb). // Specifications subject to change without notice.

1) Only for multi combinations.
Recommended fuse for the indoor 3A.

Elite



INTERNET CONTROL: Optional.

HIGH HEATING CAPACITY AT -7°C



Panel
CZ-KPY3A (size 700 x 700mm)
CZ-KPY3B (size 625 x 625mm)



Optional Controller
Wired remote controller
CZ-RTC5



Optional Controller
Timer remote controller
CZ-RTC4



Optional Controller
Wireless remote controller
CZ-RWSK2



Optional Controller
Simplified remote controller
CZ-RE2C2

Compatible with all Panasonic connectivity solutions. For detailed information go to the Control Systems section.

Elite

KIT			5,0 kW
Indoor			KIT-50PY2E5A
Outdoor			S-50PY2E5A
Panel			U-50PE1E5
Timer remote controller			CZ-KPY3A / CZ-KPY3B
Cooling capacity	Nominal (Min - Max)	kW	5,0 (1,5 - 5,6)
EER¹⁾	Nominal (Min - Max)	W/W	3,04 (5,77 - 2,29)
SEER²⁾		W/W	5,90 A
Pdesign		kW	5,0
Power input cooling	Nominal (Min - Max)	kW	1,64 (0,260 - 2,45)
Annual energy consumption (ErP)³⁾		kWh/a	297
Heating capacity	Nominal (Min - Max)	kW	5,6 (1,5 - 6,3)
Heating capacity at -7°C⁴⁾	Nominal	kW	4,20
Heating capacity at -15°C⁴⁾	Nominal	kW	3,58
COP¹⁾	Nominal (Min - Max)	W/W	3,12 (6,82 - 2,45)
SCOP⁵⁾		W/W	3,80 A
Pdesign at -10°C		kW	4,0
Power input heating	Nominal (Min - Max)	kW	1,79 (0,22 - 2,57)
Annual energy consumption (ErP)³⁾		kWh/a	1.474
Indoor unit			
Air volume	Cooling / Heating	m ³ /h	666 / 666
Moisture removal volume		l/h	2,8
Sound pressure level⁶⁾	Cooling (Hi / Me / Lo)	dB(A)	40 / 37 / 33
	Heating (Hi / Me / Lo)	dB(A)	40 / 37 / 33
Sound power level	Cooling (Hi)	dB	55 / 52 / 48
	Heating (Hi)	dB	55 / 52 / 48
Dimensions (H x W x D)	Indoor	mm	288 x 583 x 583
	Panel CZ-KPY3A / CZ-KPY3B	mm	31 x 700 x 700 / 31 x 625 x 625
Net weight	Indoor (Panel)	kg	18 (2,4)
Outdoor unit			
Power source		V	220 - 240
Recommended fuse		A	16
Connection		mm ²	2,5
Current	Cooling / Heating	A	7,5 / 8,2
Air volume	Cooling / Heating	m ³ /h	1.800 / 2.100
Sound pressure level	Cooling / Heating (Hi)	dB(A)	46 / 50
Sound power level	Cooling / Heating (Hi)	dB	65 / 69
Dimensions	H x W x D	mm	569 x 790 x 285
Net weight		kg	42
Piping connections	Liquid pipe / Gas pipe	Inch (mm)	1/4 (6,35) / 1/2 (12,7)
Refrigerant Loading	R410A	kg	1,65
Piping length range / Elevation difference (in/out)⁷⁾		m	5 - 40 / 30
Pipe length for additional gas / Additional gas amount		m / g/m	30 / 20
Operating range	Cooling Min / Max	°C	-15 / +46
	Heating Min / Max	°C	-20 / +24

Rating Conditions: Cooling Indoor 27°C DB / 19°C WB. Cooling Outdoor 35°C DB / 24°C WB. Heating Indoor 20°C DB. Heating Outdoor 7°C DB / 6°C WB. (DB: Dry Bulb; WB: Wet Bulb). // Specifications subject to change without notice.

1) EER and COP, Energy Saving Classification, is at 220 / 240 V (380 / 415 V) only in accordance with EU directive 2002/31/EC. 2) SEER is calculated in base Eurovent IPLV for SBEM for U1 indoor unit SEER=a(EER25)+b(EER50)+c(EER75)+d(EER100) where EER25, EER50, EER75 and EER100 are the EER measured value at 25%, 50%, 75% and 100% part load for temperatures 20, 25, 30 and 35°C DB, respectively. a, b, c and d are values assigned for an office type. These values are given as a=0,2, b=0,36, c=0,32 and d=0,03. The internal temperatures are taken at 27°C DB and 19°C WB. 3) The annual consumption (ErP) is calculated by formula determined by ErP regulation. 4) Heating capacity is calculated including defrost factor correction. 5) SCOP is calculated in base Eurovent IPLV for SBEM with U1 indoor unit including defrost correction factor. 6) The Sound pressure level of the units shows the value measured of a position 1 meter in front of the main body and 1,5 m from the ground. The sound pressure is measured in accordance with Eurovent 6/C/006-97 specification. 7) When installing the outdoor unit at a higher position than the indoor unit. // Recommended fuse for the indoor 3A. // For detailed information about ErP, please visit our websites www.aircon.panasonic.eu or www.ptc.panasonic.eu

Accessories



PAW-GRDST40
Outdoor elevation platform 400 x 900 x 400 mm.



PAW-WTRAY
Tray for condenser water compatible with base ground support



PAW-GRDSE20
Outdoor base ground support for noise and vibration absorption (400 x 95 x 130 mm, 500 kg)



PAW-WPH7: Wind protection shield for U-50PE1E5.
PAW-WPH6: Wind protection shield for U-200PE1E8, U-250PE1E8.
PAW-WPH9: Wind protection shield for U-60PE1E5, U-71PE1E5/R, U-100PE1E5/R, U-125PE1E5/R.
PAW-WPH10: Wind protection shield for U-100PE1E5/R, U-125PE1E5/R, U-140PE1E5/R, U-140PE1E5/R.



PAW-PCR3
Interfaces to run 3 units on Backup and alternative run.



U-50PE1E5

4 WAY 90x90 CASSETTE
PACi STANDARD AND ELITE
INVERTER+

The 4 Way 90x90 Cassette incorporates many new benefits thanks to advances in design and technology.

Technical focus

- Circle Flow Flap for more even temperature distribution
- Higher efficiency split fin
- Highly efficient and silent turbo fan
- Individual flap control for flexible air flow direction
- Easy to clean suction grill & flap
- Special adjustment for high ceiling application
- DC FAN for better efficiency and control
- Easy connection and control of external fan or ERV using the connector PAW-FDC on the indoor unit PCB. The external device can be control by the remote control of the Panasonic indoor unit

Standard

		Single Phase				Three Phase			
		6,0 kW	7,1 kW	10,0 kW	12,5 kW	10,0 kW	12,5 kW	14,0 kW	
		KIT-60PUY1E5A	KIT-71PUY1E5A	KIT-100PUY1E5A	KIT-125PUY1E5A	KIT-100PUY1E8A	KIT-125PUY1E8A	KIT-140PUY1E8A	
Indoor		S-60PU1E5A	S-71PU1E5A	S-100PU1E5A	S-125PU1E5A	S-100PU1E5A	S-125PU1E5A	S-140PU1E5A	
Outdoor		U-60PEY1E5	U-71PEY1E5	U-100PEY1E5	U-125PEY1E5	U-100PEY1E8	U-125PEY1E8	U-140PEY1E8	
Panel		CZ-KPU21	CZ-KPU21	CZ-KPU21	CZ-KPU21	CZ-KPU21	CZ-KPU21	CZ-KPU21	
Timer remote controller		CZ-RTC4	CZ-RTC4	CZ-RTC4	CZ-RTC4	CZ-RTC4	CZ-RTC4	CZ-RTC4	
Cooling capacity	Nominal (Min - Max)	kW	6,0 (2,0 - 7,0)	7,1 (2,0 - 7,7)	10,0 (2,7 - 11,5)	12,5 (3,8 - 13,5)	10,0 (2,7 - 11,5)	12,5 (3,8 - 13,5)	14,0 (3,3 - 15,5)
EER ¹⁾	Nominal (Min - Max)	W/W	3,55 (6,15 - 2,80) A	3,24 (6,15 - 2,75) A	3,11 (5,09 - 2,74) B	3,11 (4,22 - 2,70) B	3,11 (5,09 - 2,74) B	3,11 (4,22 - 2,70) B	3,21 (3,93 - 2,58) A
SEER ²⁾	Nominal (Min - Max)	W/W	6,8 A++	6,3 A++	6,4 A++	—	6,2 A++	—	—
Pdesign		kW	6,0	7,1	10	—	10,0	—	—
Power input cooling	Nominal (Min - Max)	kW	1,690 (0,325 - 2,500)	2,190 (0,325 - 2,800)	3,220 (0,530 - 4,200)	4,020 (0,900 - 5,000)	3,220 (0,530 - 4,200)	4,020 (0,900 - 5,000)	4,36 (0,84 - 6,00)
Annual energy consumption (ErP) ³⁾		kWh/a	309	394	547	—	564	—	—
Heating capacity	Nominal (Min - Max)	kW	6,0 (1,8 - 7,0)	7,1 (1,8 - 8,1)	10,0 (2,1 - 13,8)	12,5 (3,4 - 15,0)	10,0 (2,1 - 13,8)	12,5 (3,4 - 15,0)	14,0 (4,1 - 16,0)
Heating capacity at -7°C ⁴⁾		kW	4,99	5,08	9,97	10,97	9,97	10,97	13,35
Heating capacity at -15°C ⁴⁾		kW	4,20	4,37	8,43	9,03	8,43	9,03	12,38
COP ⁵⁾	Nominal (Min - Max)	W/W	4,05 (6,55 - 3,25) A	3,78 (6,55 - 3,23) A	3,80 (5,12 - 3,45) A	3,80 (4,66 - 3,41) A	3,80 (5,12 - 3,45) A	3,80 (4,66 - 3,41) A	3,89 (4,56 - 3,08) A
SCOP ⁵⁾	Nominal (Min - Max)	W/W	4,0 A+	4,0 A+	4,0 A+	—	4,0 A+	—	—
Pdesign at -10°C		kW	6,0	6,0	10,0	—	10,0	—	—
Power input heating	Nominal (Min - Max)	kW	1,480 (0,275 - 2,155)	1,880 (0,275 - 2,510)	2,630 (0,410 - 4,000)	3,290 (0,730 - 4,400)	2,630 (0,410 - 4,000)	3,290 (0,730 - 4,400)	3,60 (0,90 - 5,20)
Annual energy consumption (ErP) ³⁾		kWh/a	2.100	2.100	3.500	—	3.500	—	—
Indoor unit									
Air volume	Cooling (Hi / Med / Lo)	m³/h	1.260 / 1.020 / 840	1.320 / 1.020 / 840	1.980 / 1.620 / 1.260	2.100 / 1.680 / 1.320	1.980 / 1.620 / 1.260	2.100 / 1.680 / 1.320	2.160 / 1.740 / 1.380
	Heating (Hi / Med / Lo)	m³/h	1.260 / 1.020 / 840	1.320 / 1.020 / 840	1.980 / 1.620 / 1.260	2.100 / 1.680 / 1.320	1.980 / 1.620 / 1.260	2.100 / 1.680 / 1.320	2.160 / 1.740 / 1.380
Moisture removal volume		l/h	3,4	4,2	6,0	7,9	6,0	7,9	9,0
Sound pressure level ⁴⁾	Cooling (Hi / Med / Lo)	dB(A)	36 / 31 / 28	37 / 31 / 28	44 / 38 / 32	45 / 39 / 33	44 / 38 / 32	45 / 39 / 33	46 / 40 / 34
	Heating (Hi / Med / Lo)	dB(A)	36 / 31 / 28	37 / 31 / 28	44 / 38 / 32	45 / 39 / 33	44 / 38 / 32	45 / 39 / 33	46 / 40 / 34
Sound power level	Cooling (Hi / Med / Lo)	dB	53 / 48 / 45	54 / 48 / 45	62 / 55 / 49	63 / 56 / 50	62 / 55 / 49	63 / 56 / 50	64 / 57 / 51
	Heating (Hi / Med / Lo)	dB	53 / 48 / 45	54 / 48 / 45	62 / 55 / 49	63 / 56 / 50	62 / 55 / 49	63 / 56 / 50	64 / 57 / 51
Dimensions (H x W x D)	Indoor	mm	256 x 840 x 840	256 x 840 x 840	319 x 840 x 840	319 x 840 x 840	319 x 840 x 840	319 x 840 x 840	319 x 840 x 840
	Panel	mm	33,5 x 950 x 950	33,5 x 950 x 950	33,5 x 950 x 950	33,5 x 950 x 950	33,5 x 950 x 950	33,5 x 950 x 950	33,5 x 950 x 950
Net weight	Indoor (Panel)	kg	24 (4)	24 (4)	27 (4)	27 (4)	27 (4)	27 (4)	27 (4)
Outdoor unit									
Power source		V	220 / 230 / 240	220 / 230 / 240	220 / 230 / 240	220 / 230 / 240	380 / 400 / 415	380 / 400 / 415	380 / 400 / 415
Recommended fuse		A	20	20	25	30	16	16	16
Connection		mm²	2,5	2,5	4	6	2,5	2,5	2,5
Current	Cooling	A	8,30 / 7,90 / 7,60	10,70 / 10,30 / 9,80	15,10 / 14,40 / 13,80	19,2 / 18,4 / 17,6	5,10 / 4,85 / 4,70	6,35 / 6,05 / 5,80	6,85 / 6,50 / 6,25
	Heating	A	7,20 / 6,90 / 6,60	9,10 / 8,70 / 8,30	12,00 / 11,60 / 11,20	15,4 / 14,8 / 14,2	4,15 / 3,95 / 3,80	5,15 / 4,90 / 4,70	5,65 / 5,35 / 5,20
Air volume	Cooling / Heating	m³/h	1.800 / 2.100	2340	4.560 / 4.020	4.800 / 4.380	4.560 / 4.020	4.800 / 4.380	8.100 / 7.200
Sound pressure level	Cooling / Heating (Hi)	dB(A)	46 / 50	50 / 52	54 / 54	56 / 56	54 / 54	56 / 56	54 / 53
Sound power level	Cooling / Heating (Hi)	dB	65 / 69	70 / 70	70 / 70	73 / 73	70 / 70	73 / 73	71 / 70
Dimensions	H x W x D	mm	569 x 790 x 285	569 x 790 x 285	996 x 940 x 340	996 x 940 x 340	996 x 940 x 340	996 x 940 x 340	1.416 x 940 x 340
Net weight		kg	42	42	73	85	73	85	98
Piping connections	Liquid pipe / Gas pipe	Inch (mm)	3/8 (9,52) / 5/8 (15,88)	3/8 (9,52) / 5/8 (15,88)	3/8 (9,52) / 5/8 (15,88)	3/8 (9,52) / 5/8 (15,88)	3/8 (9,52) / 5/8 (15,88)	3/8 (9,52) / 5/8 (15,88)	3/8 (9,52) / 5/8 (15,88)
Refrigerant loading	R410A	kg	1,7	1,7	2,60	3,20	2,60	3,20	3,4
Piping length range / Elevation difference (in/out) ⁷⁾		m	5 - 50 / 30	5 - 50 / 30	5 - 50 / 30	5 - 50 / 30	5 - 50 / 30	5 - 50 / 30	5 - 50 / 30
Pipe length for additional gas / Additional gas amount		m / g/m	20 / 40	20 / 40	30 / 50	30 / 50	30 / 50	30 / 50	30 / 50
Operating range	Cooling Min / Max	°C	-10 / +43	-10 / +43	-10 / +43	-10 / +43	-10 / +43	-10 / +43	-10 / +43
	Heating Min / Max	°C	-15 / +24	-15 / +24	-15 / +24	-15 / +24	-15 / +24	-15 / +24	-15 / +24

Rating Conditions: Cooling Indoor 27°C DB / 19°C WB. Cooling Outdoor 35°C DB / 24°C WB. Heating Indoor 20°C DB. Heating Outdoor 7°C DB / 6°C WB. (DB: Dry Bulb; WB: Wet Bulb). // Specifications subject to change without notice.
 1) EER and COP, Energy Saving Classification, is at 220 / 240 V (380 / 415 V) only in accordance with EU directive 2002/31/EC. 2) SEER is calculated in base Eurovent IPLV for SBEM for U1 indoor unit SEER=a(EER25)+b(EER50)+c(EER75)+d(EER100) where EER25, EER50, EER75 and EER100 are the EER measured value at 25%, 50%, 75% and 100% part load for temperatures 20, 25, 30 and 35°C DB, respectively. a, b, c and d are values assigned for an office type. These values are given as a=0,2, b=0,36, c=0,32 and d=0,03. The internal temperatures are taken at 27°C DB and 19°C WB. 3) The annual consumption(ErP) is calculated by formula determined by ErP regulation. 4) Heating capacity is calculated including defrost factor correction. 5) SCOP is calculated in base Eurovent IPLV for SBEM with U1

Standard

Elite

A++ 6,80 SEER	A+ 4,00 SCOP	-10°C COOLING MODE	-15°C HEATING MODE	A++ 7,40 SEER	A+ 4,10 SCOP	-15°C COOLING MODE	-20°C HEATING MODE	INVERTER+	DC FAN	R22 RENEWAL R22 RENEWAL R410A	INTERNET CONTROL	CONNECTIVITY BMS	5 YEARS COMPRESSOR WARRANTY
-------------------------	------------------------	------------------------------	------------------------------	-------------------------	------------------------	------------------------------	------------------------------	------------------	---------------	---	-------------------------	----------------------------	------------------------------------

SEER and SCOP: For KIT-60PUY1E5A.

SEER and SCOP: For KIT-60PUY1E5A and KIT-71PUY1E5A.

INTERNET CONTROL: Optional.

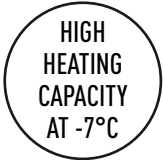

Panel
CZ-KPU21



360°
air flow



Optional Controller
Wired remote controller
CZ-RTC5



Optional Controller
Timer remote controller
CZ-RTC4



Optional Controller
Wireless remote controller
CZ-RWSU2N



Optional Controller
Simplified remote controller
CZ-RE2C2

Compatible with all Panasonic connectivity solutions. For detailed information go to the Control Systems section.

Elite

Single Phase						Three Phase			
5,0 kW	6,0 kW	7,1 kW	10,0 kW	12,5 kW	14,0 kW	7,1 kW	10,0 kW	12,5 kW	14,0 kW
KIT-50PU1E5A	KIT-60PU1E5A	KIT-71PU1E5A	KIT-100PU1E5A	KIT-125PU1E5A	KIT-140PU1E5A	KIT-71PU1E8A	KIT-100PU1E8A	KIT-125PU1E8A	KIT-140PU1E8A
S-50PU1E5A	S-60PU1E5A	S-71PU1E5A	S-100PU1E5A	S-125PU1E5A	S-140PU1E5A	S-71PU1E8A	S-100PU1E8A	S-125PU1E8A	S-140PU1E8A
U-50PE1E5	U-60PE1E5A	U-71PE1E5A	U-100PE1E5A	U-125PE1E5A	U-140PE1E5A	U-71PE1E8A	U-100PE1E8A	U-125PE1E8A	U-140PE1E8A
CZ-KPU21	CZ-KPU21	CZ-KPU21	CZ-KPU21	CZ-KPU21	CZ-KPU21	CZ-KPU21	CZ-KPU21	CZ-KPU21	CZ-KPU21
CZ-RTC4	CZ-RTC4	CZ-RTC4	CZ-RTC4	CZ-RTC4	CZ-RTC4	CZ-RTC4	CZ-RTC4	CZ-RTC4	CZ-RTC4
5,0 (1,5 - 5,6)	6,0 (2,5 - 7,1)	7,1 (2,5 - 8,0)	10,0 (3,3 - 12,5)	12,5 (3,3 - 14,0)	14,0 (3,3 - 15,5)	7,1 (3,2 - 8,0)	10,0 (3,3 - 12,5)	12,5 (3,3 - 14,0)	14,0 (3,3 - 15,5)
3,70 (5,77 - 2,80) A	4,05 (5,56 - 3,55) A	3,94 (5,56 - 3,02) A	4,20 (3,93 - 3,38) A	3,60 (3,93 - 3,04) A	3,25 (3,93 - 2,58) A	3,94 (5,56 - 3,02) A	4,20 (3,93 - 3,38) A	3,60 (3,93 - 3,04) A	3,25 (3,93 - 2,58) A
6,5 A++	7,4 A++	7,4 A++	6,6 A++	—	—	6,8 A++	6,5 A++	—	—
5,0	6,0	7,1	10,0	—	—	7,1	10,0	—	—
1,350 (0,260 - 2,000)	1,480 (0,450 - 2,000)	1,800 (0,450 - 2,650)	2,380 (0,840 - 3,700)	3,470 (0,840 - 4,600)	4,310 (0,840 - 6,000)	1,800 (0,560 - 2,650)	2,380 (0,840 - 3,700)	3,470 (0,840 - 4,600)	4,310 (0,840 - 6,000)
269	284	336	530	—	—	365	538	—	—
5,6 (1,5 - 6,5)	7,0 (2,0 - 8,0)	8,0 (2,0 - 9,0)	11,2 (4,1 - 14,0)	14,0 (4,1 - 16,0)	16,0 (4,1 - 18,0)	8,0 (2,8 - 9,0)	11,2 (4,1 - 14,0)	14,0 (4,1 - 16,0)	16,0 (4,1 - 18,0)
4,20	6,69	7,52	12,04	13,48	14,24	7,52	12,04	13,48	14,24
3,58	6,56	7,65	11,20	12,38	12,69	7,65	11,20	12,38	12,69
3,92 (6,82 - 2,83) A	3,87 (5,00 - 3,23) A	4,00 (5,00 - 3,10) A	4,31 (4,56 - 3,18) A	4,00 (4,56 - 3,08) A	3,70 (4,56 - 3,05) A	4,00 (5,60 - 3,10) A	4,31 (4,56 - 3,18) A	4,00 (4,56 - 3,08) A	3,70 (4,56 - 3,05) A
3,8 A	4,1 A+	4,1 A+	4,2 A+	—	—	4,0 A+	4,2 A+	—	—
4,0	6,0	7,1	10,0	—	—	7,1	10,0	—	—
1,430 (0,220 - 2,300)	1,810 (0,400 - 2,480)	2,000 (0,400 - 2,900)	2,600 (0,900 - 4,400)	3,500 (0,900 - 5,200)	4,330 (0,900 - 5,900)	2,000 (0,500 - 2,900)	2,600 (0,900 - 4,400)	3,500 (0,900 - 5,200)	4,330 (0,900 - 5,900)
1,474	2,047	2,424	3,333	—	—	2,485	3,333	—	—
960 / 810 / 720	1.260 / 1.020 / 840	1.320 / 1.020 / 840	1.980 / 1.620 / 1.260	2.100 / 1.680 / 1.320	2.160 / 1.740 / 1.380	1.320 / 1.020 / 840	1.980 / 1.620 / 1.260	2.100 / 1.680 / 1.320	2.160 / 1.740 / 1.380
960 / 810 / 720	1.260 / 1.020 / 840	1.320 / 1.020 / 840	1.980 / 1.620 / 1.260	2.100 / 1.680 / 1.320	2.160 / 1.740 / 1.380	1.320 / 1.020 / 840	1.980 / 1.620 / 1.260	2.100 / 1.680 / 1.320	2.160 / 1.740 / 1.380
2,8	3,4	4,2	6,0	7,9	9,0	4,2	6,0	7,9	9,0
32 / 29 / 27	36 / 31 / 28	37 / 31 / 28	44 / 38 / 32	45 / 39 / 33	46 / 40 / 34	37 / 31 / 28	44 / 38 / 32	45 / 39 / 33	46 / 40 / 34
32 / 29 / 27	36 / 31 / 28	37 / 31 / 28	44 / 38 / 32	45 / 39 / 33	46 / 40 / 34	37 / 31 / 28	44 / 38 / 32	45 / 39 / 33	46 / 40 / 34
49 / 46 / 44	53 / 48 / 45	54 / 48 / 45	62 / 55 / 49	63 / 56 / 50	64 / 57 / 51	54 / 48 / 45	62 / 55 / 49	63 / 56 / 50	64 / 57 / 51
49 / 46 / 44	53 / 48 / 45	54 / 48 / 45	62 / 55 / 49	63 / 56 / 50	64 / 57 / 51	54 / 48 / 45	62 / 55 / 49	63 / 56 / 50	64 / 57 / 51
256 x 840 x 840	256 x 840 x 840	256 x 840 x 840	319 x 840 x 840	319 x 840 x 840	319 x 840 x 840	256 x 840 x 840	319 x 840 x 840	319 x 840 x 840	319 x 840 x 840
33,5 x 950 x 950	33,5 x 950 x 950	33,5 x 950 x 950	33,5 x 950 x 950	33,5 x 950 x 950	33,5 x 950 x 950	33,5 x 950 x 950	33,5 x 950 x 950	33,5 x 950 x 950	33,5 x 950 x 950
23 (4)	24 (4)	24 (4)	27 (4)	27 (4)	27 (4)	24 (4)	27 (4)	27 (4)	27 (4)
220 / 230 / 240	220 / 230 / 240	220 / 230 / 240	220 / 230 / 240	220 / 230 / 240	220 / 230 / 240	380 / 400 / 415	380 / 400 / 415	380 / 400 / 415	380 / 400 / 415
16	20	20	25	30	220 / 230 / 240	16	16	16	16
2,5	2,5	2,5	4	6	2,5	2,5	2,5	2,5	2,5
6,50 / 6,20 / 5,95	7,15 / 6,90 / 6,70	8,40 / 8,10 / 7,90	10,7 / 10,3 / 9,90	15,8 / 15,3 / 14,8	19,6 / 19,0 / 18,4	2,80 / 2,70 / 2,60	3,70 / 3,50 / 3,40	5,45 / 5,15 / 5,00	6,75 / 6,45 / 6,20
6,90 / 6,60 / 6,30	8,50 / 8,20 / 7,95	9,30 / 9,00 / 8,70	11,8 / 11,4 / 11,0	15,9 / 15,4 / 14,9	19,8 / 19,2 / 18,6	3,10 / 3,00 / 2,90	4,05 / 3,85 / 3,75	5,50 / 5,20 / 5,05	6,85 / 6,50 / 6,25
1.800 / 2.100	3.600 / 3.600	3.600 / 3.600	6.600 / 5.700	7.800 / 6.600	8.100 / 7.200	3.600 / 3.600	6.600 / 5.700	7.800 / 6.600	8.100 / 7.200
46 / 50	48 / 50	48 / 50	52 / 52	53 / 53	54 / 55	48 / 50	52 / 52	53 / 53	54 / 55
65 / 69	65 / 67	65 / 67	69 / 69	70 / 70	71 / 71	65 / 67	69 / 69	70 / 70	71 / 71
569 x 790 x 285	996 x 940 x 340	996 x 940 x 340	1.416 x 940 x 340	1.416 x 940 x 340	1.416 x 940 x 340	569 x 790 x 285	996 x 940 x 340	996 x 940 x 340	1.416 x 940 x 340
42	68	69	98	98	98	71	98	98	98
1/4 (6,35) / 1/2 (12,7)	3/8 (9,52) / 5/8 (15,88)	3/8 (9,52) / 5/8 (15,88)	3/8 (9,52) / 5/8 (15,88)	3/8 (9,52) / 5/8 (15,88)	3/8 (9,52) / 5/8 (15,88)	3/8 (9,52) / 5/8 (15,88)	3/8 (9,52) / 5/8 (15,88)	3/8 (9,52) / 5/8 (15,88)	3/8 (9,52) / 5/8 (15,88)
1,65	2	2,35	3,4	3,4	3,4	2,35	3,4	3,4	3,4
5 - 40 / 30	5 - 50 / 30	5 - 50 / 30	5 - 75 / 30	5 - 75 / 30	5 - 75 / 30	5 - 50 / 30	5 - 75 / 30	5 - 75 / 30	5 - 75 / 30
30 / 20	30 / 50	30 / 50	30 / 50	30 / 50	30 / 50	30 / 50	30 / 50	30 / 50	30 / 50
-15 / +46	-15 / +46	-15 / +46	-15 / +46	-15 / +46	-15 / +46	-15 / +46	-15 / +46	-15 / +46	-15 / +46
-20 / +24	-20 / +24	-20 / +24	-20 / +24	-20 / +24	-20 / +24	-20 / +24	-20 / +24	-20 / +24	-20 / +24

indoor unit including defrost correction factor. 6) The Sound pressure level of the units shows the value measured of a position 1 meter in front of the main body and 1,5 m from the ground. The sound pressure is measured in accordance with Eurovent 6/C/006-97 specification. 7) When installing the outdoor unit at a higher position than the indoor unit. // Recommended fuse for the indoor 3A. For detailed information about ErP, please visit our websites www.aircon.panasonic.eu or www.ptc.panasonic.eu

Accessories



PAN-GRDSTd0
Outdoor elevation platform 400 x 900 x 400 mm.



PAN-WTRAY
Tray for condenser water compatible with base ground support



PAN-GRDSE20
Outdoor base ground support for noise and vibration absorption (600 x 95 x 130 mm, 500 kg)



PAN-WPH7: Wind protection shield for U-50PE1E5, U-71PE1E5, U-100PE1E5, U-125PE1E5, U-140PE1E5.
PAN-WPH8: Wind protection shield for U-200PE1E8, U-250PE1E8.
PAN-WPH9: Wind protection shield for U-60PE1E5, U-71PE1E5, U-100PE1E5, U-125PE1E5.
PAN-WPH10: Wind protection shield for U-100PE1E5, U-125PE1E5, U-140PE1E5, U-140PE1E8.



PAN-PACR3
Interfaces to run 3 units on Backup and alternative run.



U-60PE1E5
U-71PE1E5
U-50PE1E5



U-100PE1E5
U-125PE1E5
U-140PE1E8



U-60PE1E8
U-71PE1E8A
U-140PE1E8
U-100PE1E8A
U-125PE1E8A
U-140PE1E8A

LOW STATIC PRESSURE HIDE AWAY PACi STANDARD AND ELITE INVERTER+

The depth of only 250mm provides greater installation flexibility and the unit can be used in more applications. Ideal for sites with narrow ceiling voids.

Technical focus

- Compact indoor units without losing static pressure (Only 250 mm high)
- 50 Pa static pressure
- Easy maintenance and service via external electrical box
- 3 speed centrifugal fan through wired or wireless remote control
- DC FAN for better efficiency and control
- Easy connection and control of external fan or ERV using the connector PAW-FDC on the indoor unit PCB. The external device can be control by the remote control of the Panasonic indoor unit

Standard

		Single Phase				Three Phase			
		6,0 kW	7,1 kW	10,0 kW	12,5 kW	10,0 kW	12,5 kW	14,0 kW	
KIT		KIT-60PN1E5A	KIT-71PN1E5A	KIT-100PN1E5A	KIT-125PN1E5A	KIT-100PN1E8A	KIT-125PN1E8A	KIT-140PN1E8A	
Indoor		S-60PN1E5A	S-71PN1E5A	S-100PN1E5A	S-125PN1E5A	S-100PN1E5A	S-125PN1E5A	S-140PN1E5A	
Outdoor		U-60PEY1E5	U-71PEY1E5	U-100PEY1E5	U-125PEY1E5	U-100PEY1E8	U-125PEY1E8	U-140PEY1E8	
Timer remote controller		CZ-RTC4	CZ-RTC4	CZ-RTC4	CZ-RTC4	CZ-RTC4	CZ-RTC4	CZ-RTC4	
Cooling capacity	Nominal (Min - Max)	kW	6,0 (2,0 - 7,0)	7,1 (2,0 - 7,7)	10,0 (2,7 - 11,5)	12,5 (3,8 - 13,5)	10,0 (2,7 - 11,5)	12,5 (3,8 - 13,5)	14,0 (3,3 - 15,5)
EER ¹⁾	Nominal (Min - Max)	W/W	3,02 (6,15 - 2,38) B	2,76 (6,15 - 2,38) D	2,81 (4,74 - 2,67) C	2,81 (4,00 - 2,60) C	2,81 (4,74 - 2,67) C	2,98 (3,93 - 2,58) C	
SEER ²⁾	Nominal (Min - Max)	W/W	4,7 B	5,0 B	5,3 A	—	5,2 A	—	
Pdesign		kW	6,0	7,1	10,0	—	10,0	—	
Power input cooling	Nominal (Min - Max)	kW	1,990 (0,325 - 2,940)	2,570 (0,325 - 3,230)	3,555 (0,570 - 4,300)	4,445 (0,950 - 5,200)	3,555 (0,570 - 4,300)	4,445 (0,950 - 5,200)	4,700 (0,840 - 6,000)
Annual energy consumption (ErP) ³⁾		kWh/a	444	496	660	—	673	—	
Heating capacity	Nominal (Min - Max)	kW	6,0 (1,8 - 7,0)	7,1 (1,8 - 8,1)	10,0 (2,1 - 13,8)	12,5 (3,4 - 15,0)	10,0 (2,1 - 13,8)	12,5 (3,4 - 15,0)	14,0 (4,1 - 16,0)
Heating capacity at -7°C ⁴⁾	Nominal	kW	4,99	5,08	9,97	10,97	9,97	13,35	
Heating capacity at -15°C ⁴⁾	Nominal	kW	4,20	4,37	8,43	9,03	8,43	12,38	
COP ¹⁾	Nominal (Min - Max)	W/W	3,61 (6,55 - 2,89) A	3,41 (6,55 - 2,91) B	3,41 (4,67 - 3,37) B	3,41 (4,36 - 3,26) B	3,41 (4,67 - 3,37) B	3,41 (4,36 - 3,26) B	3,52 (4,56 - 3,08) B
SCOP ⁵⁾	Nominal (Min - Max)	W/W	3,8 A	3,8 A	3,8 A	—	3,8 A	—	
Pdesign at -10°C		kW	4,8	5,3	7,6	—	7,6	—	
Power input heating	Nominal (Min - Max)	kW	1,660 (0,275 - 2,420)	2,080 (0,275 - 2,780)	2,935 (0,450 - 4,100)	3,665 (0,780 - 4,600)	2,935 (0,450 - 4,100)	3,665 (0,780 - 4,600)	3,880 (1,050 - 5,400)
Annual energy consumption (ErP) ³⁾		kWh/a	1.757	1.952	2.800	—	2.800	—	
Indoor unit									
External static pressure ⁶⁾	Nominal (Min - Max)	Pa	50 (10 - 80)	50 (10 - 80)	50 (10 - 80)	50 (10 - 80)	50 (10 - 80)	50 (10 - 80)	
Air volume	Cooling / Heating	m³/h	1.320 / 1.320	1.320 / 1.320	2.160 / 2.160	2.280 / 2.280	2.160 / 2.160	2.280 / 2.280	2.400 / 2.400
Moisture removal volume		l/h	3,4	4,2	6,0	7,9	6,0	7,9	9,0
Sound pressure level ⁷⁾	Cooling (Hi / Med / Lo)	dB(A)	43 / 41 / 36	43 / 41 / 36	44 / 42 / 37	45 / 43 / 38	44 / 42 / 37	45 / 43 / 38	46 / 44 / 39
	Heating (Hi / Med / Lo)	dB(A)	43 / 41 / 36	43 / 41 / 36	44 / 42 / 37	45 / 43 / 38	44 / 42 / 37	45 / 43 / 38	46 / 44 / 39
Sound power level	Cooling (Hi / Med / Lo)	dB	60 / 58 / 53	60 / 58 / 53	65 / 63 / 58	66 / 64 / 59	65 / 63 / 58	66 / 64 / 59	67 / 65 / 60
	Heating (Hi / Med / Lo)	dB	60 / 58 / 53	60 / 58 / 53	65 / 63 / 58	66 / 64 / 59	65 / 63 / 58	66 / 64 / 59	67 / 65 / 60
Dimensions ⁸⁾	H x W x D	mm	250 x 1.000 x 650	250 x 1.000 x 650	250 x 1.200 x 650	250 x 1.200 x 650	250 x 1.200 x 650	250 x 1.200 x 650	250 x 1.200 x 650
Net weight		kg	32	32	41	41	41	41	
Outdoor unit									
Power source	V		220 / 230 / 240	220 / 230 / 240	220 / 230 / 240	220 / 230 / 240	380 / 400 / 415	380 / 400 / 415	380 / 400 / 415
Recommended fuse	A		20	20	25	30	16	16	16
Connection	mm²		2,5	2,5	4	6	2,5	2,5	2,5
Current	Cooling	A	9,1 / 8,7 / 8,4	12,0 / 11,5 / 11,0	16,0 / 15,3 / 14,8	20,1 / 19,3 / 18,7	5,45 / 5,20 / 5,05	6,85 / 6,50 / 6,25	7,05 / 6,70 / 6,45
	Heating	A	7,5 / 7,2 / 6,9	9,6 / 9,2 / 8,9	13,0 / 12,5 / 12,1	16,5 / 15,8 / 15,2	4,45 / 4,25 / 4,10	5,55 / 5,30 / 5,10	5,90 / 5,60 / 5,40
Air volume	Cooling / Heating	m³/h	1.800 / 2.100	2.340	4.560 / 4.020	4.800 / 4.380	4.560 / 4.020	4.800 / 4.380	8.100 / 7.200
Sound pressure level	Cooling / Heating (Hi)	dB(A)	46 / 50	50 / 52	54 / 54	56 / 56	54 / 54	56 / 56	54 / 53
Sound power level	Cooling / Heating (Hi)	dB	65 / 69	70 / 70	70 / 70	73 / 73	70 / 70	73 / 73	71 / 70
Dimensions	H x W x D	mm	569 x 790 x 285	569 x 790 x 285	996 x 940 x 340	996 x 940 x 340	996 x 940 x 340	996 x 940 x 340	1.416 x 940 x 340
Net weight		kg	42	42	73	85	73	85	98
Piping connections	Liquid pipe	Inch (mm)	3/8 (9,52)	3/8 (9,52)	3/8 (9,52)	3/8 (9,52)	3/8 (9,52)	3/8 (9,52)	3/8 (9,52)
	Gas pipe	Inch (mm)	5/8 (15,88)	5/8 (15,88)	5/8 (15,88)	5/8 (15,88)	5/8 (15,88)	5/8 (15,88)	5/8 (15,88)
Refrigerant loading	R410A	kg	1,7	1,7	2,60	3,20	2,60	3,20	3,4
Piping length / Elevation difference (in/out) ⁹⁾	m		5 - 50 / 30	5 - 50 / 30	5 - 50 / 30	5 - 50 / 30	5 - 50 / 30	5 - 50 / 30	5 - 50 / 30
Pipe length for additional gas / Additional gas amount	m / g/m		20 / 40	20 / 40	30 / 50	30 / 50	30 / 50	30 / 50	30 / 50
Operating range	Cooling Min / Max	°C	-10 / +43	-10 / +43	-10 / +43	-10 / +43	-10 / +43	-10 / +43	-10 / +43
	Heating Min / Max	°C	-15 / +24	-15 / +24	-15 / +24	-15 / +24	-15 / +24	-15 / +24	-15 / +24

Rating Conditions: Cooling Indoor 27°C DB / 19°C WB. Cooling Outdoor 35°C DB / 24°C WB. Heating Indoor 20°C DB. Heating Outdoor 7°C DB / 6°C WB. (DB: Dry Bulb; WB: Wet Bulb). // Specifications subject to change without notice.

1) EER and COP, Energy Saving Classification, is at 220 / 240 V (380 / 415 V) only in accordance with EU directive 2002/31/EC. 2) SEER is calculated in base Eurovent IPLV for SBEM for U1 indoor unit SEER=a(EER25)+b(EER50)+c(EER75)+d(EER100) where EER25, EER50, EER75 and EER100 are the EER measured value at 25%, 50%, 75% and 100% part load for temperatures 20, 25, 30 and 35°C DB, respectively. a, b, c and d are values assigned for an office type. These values are given as a=0,2, b=0,36, c=0,32 and d=0,03. The internet temperatures are taken at 27°C DB and 19°C WB. 3) The annual consumption(ErP) is calculated by formula determined by ErP regulation. 4) Heating capacity is calculated including defrost factor correction. 5) SCOP is calculated in base Eurovent IPLV for SBEM with U1

Standard

Elite



SEER and SCOP: For KIT-100PN1E5A.

SEER and SCOP: For KIT-100PN1E5A.

INTERNET CONTROL: Optional.

**HIGH STATIC PRESSURE
HIDE AWAY
PACi STANDARD AND ELITE
INVERTER+**

The ducted systems are the ideal solution for flexible, concealed air conditioning and the optional 200mm spigots ensure simple, hassle-free connection to spiral ductwork.

Technical focus

- Extremely quiet operation from 26 dB(A)
- Auto restart after power failure
- Auto changeover
- Twin, triple and double-twin split options
- DC FAN for better efficiency and control
- Built in drain pump
- Easy connection and control of external fan or ERV using the connector PAW-FDC on the indoor unit PCB. The external device can be control by the remote control of the Panasonic indoor unit

Standard

		Single Phase				Three Phase			
		6,0 kW	7,1 kW	10,0 kW	12,5 kW	10,0 kW	12,5 kW	14,0 kW	
KIT		KIT-60PFY1E5A	KIT-71PFY1E5A	KIT-100PFY1E5A	KIT-125PFY1E5A	KIT-100PFY1E8A	KIT-125PFY1E8A	KIT-140PFY1E8A	
Indoor		S-60PF1E5A	S-71PF1E5A	S-100PF1E5A	S-125PF1E5A	S-100PF1E5A	S-125PF1E5A	S-140PF1E5A	
Outdoor		U-60PEY1E5	U-71PEY1E5	U-100PEY1E5	U-125PEY1E5	U-100PEY1E8	U-125PEY1E8	U-140PEY1E8	
Timer remote controller		CZ-RTC4	CZ-RTC4	CZ-RTC4	CZ-RTC4	CZ-RTC4	CZ-RTC4	CZ-RTC4	
Cooling capacity	Nominal (Min - Max)	kW	6,0 (2,0 - 7,0)	7,1 (2,0 - 7,7)	10,0 (2,7 - 11,5)	12,5 (3,8 - 13,5)	10,0 (2,7 - 11,5)	12,5 (3,8 - 13,5)	14,0 (3,3 - 15,5)
EER ¹⁾	Nominal (Min - Max)	W/W	3,10 (6,15 - 2,46) B	2,76 (6,15 - 2,35) D	3,01 (5,09 - 2,74) B	3,05 (4,22 - 2,70) B	3,01 (5,09 - 2,74) B	3,05 (4,22 - 2,70) B	3,22 (3,93 - 2,58) A
SEER ²⁾	Nominal (Min - Max)	W/W	5,4 A	5,3 A	5,4 A	—	5,2 A	—	
Pdesign		kW	6,0	7,1	10,0	—	10,0	—	
Power input cooling	Nominal (Min - Max)	kW	1,930 (0,325 - 2,850)	2,570 (0,325 - 3,270)	3,320 (0,530 - 4,200)	4,100 (0,900 - 5,000)	3,320 (0,530 - 4,200)	4,100 (0,900 - 5,000)	4,350 (0,840 - 6,000)
Annual energy consumption (ErP) ³⁾		kWh/a	389	469	648	—	673	—	
Heating capacity	Nominal (Min - Max)	kW	6,0 (1,8 - 7,0)	7,1 (1,8 - 8,1)	10,0 (2,1 - 13,8)	12,5 (3,4 - 15,0)	10,0 (2,1 - 13,8)	12,5 (3,4 - 15,0)	14,0 (4,1 - 16,0)
Heating capacity at -7°C ⁴⁾	Nominal	kW	4,99	5,08	9,97	10,97	9,97	10,97	13,35
Heating capacity at -15°C ⁴⁾	Nominal	kW	4,20	4,37	8,43	9,03	8,43	9,03	12,38
COP ¹⁾	Nominal (Min - Max)	W/W	4,25 (6,55 - 3,41) A	3,94 (6,55 - 3,40) A	3,80 (5,12 - 3,45) A	3,82 (4,66 - 3,41) A	3,80 (5,12 - 3,45) A	3,82 (4,66 - 3,41) A	3,91 (4,56 - 3,08) A
SCOP ⁵⁾	Nominal (Min - Max)	W/W	3,8 A	3,8 A	3,8 A	—	3,8 A	—	
Pdesign at -10°C		kW	5,0	5,5	9,5	—	9,5	—	
Power input heating	Nominal (Min - Max)	kW	1,410 (0,275 - 2,055)	1,800 (0,275 - 2,380)	2,630 (0,410 - 4,000)	3,270 (0,730 - 4,400)	2,630 (0,410 - 4,000)	3,270 (0,730 - 4,400)	3,580 (0,900 - 5,200)
Annual energy consumption (ErP) ³⁾		kWh/a	1.842	2.026	3.500	—	3.500	—	
Indoor unit									
External static pressure ⁶⁾	Nominal (Min - Max)	Pa	70 (10 - 150)	70 (10 - 150)	100 (10 - 150)	100 (10 - 150)	100 (10 - 150)	100 (10 - 150)	100 (10 - 150)
Air volume	Cooling (Hi / Med / Lo)	m³/h	1.260 / 1.140 / 900	1.260 / 1.140 / 900	1.920 / 1.560 / 1.260	2.040 / 1.740 / 1.380	1.920 / 1.560 / 1.260	2.040 / 1.740 / 1.380	2.160 / 1.920 / 1.500
	Heating (Hi / Med / Lo)	m³/h	1.260 / 1.140 / 900	1.260 / 1.140 / 900	1.920 / 1.560 / 1.260	2.040 / 1.740 / 1.380	1.920 / 1.560 / 1.260	2.040 / 1.740 / 1.380	2.160 / 1.920 / 1.500
Moisture removal volume		l/h	3,4	4,2	6,0	7,9	6,0	7,9	9,0
Sound pressure level ⁷⁾	Cooling (Hi / Med / Lo)	dB(A)	35 / 32 / 26	35 / 32 / 26	38 / 34 / 31	39 / 35 / 32	38 / 34 / 31	39 / 35 / 32	40 / 36 / 33
	Heating (Hi / Med / Lo)	dB(A)	35 / 32 / 26	35 / 32 / 26	38 / 34 / 31	39 / 35 / 32	38 / 34 / 31	39 / 35 / 32	40 / 36 / 33
Sound power level	Cooling (Hi / Med / Lo)	dB	57 / 54 / 48	57 / 54 / 48	60 / 56 / 53	61 / 57 / 54	60 / 56 / 53	61 / 57 / 54	62 / 58 / 55
	Heating (Hi / Med / Lo)	dB	57 / 54 / 48	57 / 54 / 48	60 / 56 / 53	61 / 57 / 54	60 / 56 / 53	61 / 57 / 54	62 / 58 / 55
Dimensions	H x W x D	mm	290 x 1.000 x 700	290 x 1.000 x 700	290 x 1.400 x 700	290 x 1.400 x 700	290 x 1.400 x 700	290 x 1.400 x 700	290 x 1.400 x 700
Net weight		kg	33	33	45	45	45	45	45
Outdoor unit									
Power source	V		220 / 230 / 240	220 / 230 / 240	220 / 230 / 240	220 / 230 / 240	380 / 400 / 415	380 / 400 / 415	380 / 400 / 415
Recommended fuse	A		20	20	25	30	16	16	16
Connection	mm²		2,5	2,5	4	6	2,5	2,5	2,5
Current	Cooling	A	9,00 / 8,65 / 8,30	12,2 / 11,7 / 11,2	15,1 / 14,5 / 13,9	18,8 / 18,0 / 17,2	5,10 / 4,85 / 4,70	6,20 / 5,90 / 5,70	6,75 / 6,45 / 6,25
	Heating	A	6,40 / 6,10 / 5,90	8,30 / 7,90 / 7,60	11,8 / 11,2 / 10,7	14,6 / 14,0 / 13,4	4,05 / 3,80 / 3,65	4,90 / 4,65 / 4,50	5,60 / 5,40 / 5,20
Air volume	Cooling / Heating	m³/h	1.800 / 2.100	2.340 / 2.340	4.560 / 4.020	4.800 / 4.380	4.560 / 4.020	4.800 / 4.380	8.100 / 7.200
Sound pressure level	Cooling / Heating (Hi)	dB(A)	46 / 50	50 / 52	54 / 54	56 / 56	54 / 54	56 / 56	54 / 53
Sound power level	Cooling / Heating (Hi)	dB	65 / 69	70 / 70	70 / 70	73 / 73	70 / 70	73 / 73	71 / 70
Dimensions	H x W x D	mm	569 x 790 x 285	569 x 790 x 285	996 x 940 x 340	996 x 940 x 340	996 x 940 x 340	996 x 940 x 340	1.416 x 940 x 340
Net weight		kg	42	42	73	85	73	85	98
Piping connections	Liquid pipe	Inch (mm)	3/8 (9,52)	3/8 (9,52)	3/8 (9,52)	3/8 (9,52)	3/8 (9,52)	3/8 (9,52)	3/8 (9,52)
	Gas pipe	Inch (mm)	5/8 (15,88)	5/8 (15,88)	5/8 (15,88)	5/8 (15,88)	5/8 (15,88)	5/8 (15,88)	5/8 (15,88)
Refrigerant loading	R410A	kg	1,7	1,7	2,60	3,20	2,60	3,20	3,4
Piping length / Elevation difference (in/out) ⁸⁾	m		5 - 50 / 30	5 - 50 / 30	5 - 50 / 30	5 - 50 / 30	5 - 50 / 30	5 - 50 / 30	5 - 50 / 30
Pipe length for additional gas / Additional gas amount	m / g/m		20 / 40	20 / 40	30 / 50	30 / 50	30 / 50	30 / 50	30 / 50
Operating range	Cooling Min / Max	°C	-10 / +43	-10 / +43	-10 / +43	-10 / +43	-10 / +43	-10 / +43	-10 / +43
	Heating Min / Max	°C	-15 / +24	-15 / +24	-15 / +24	-15 / +24	-15 / +24	-15 / +24	-15 / +24

Rating Conditions: Cooling Indoor 27°C DB / 19°C WB. Cooling Outdoor 35°C DB / 24°C WB. Heating Indoor 20°C DB. Heating Outdoor 7°C DB / 6°C WB. (DB: Dry Bulb; WB: Wet Bulb). // Specifications subject to change without notice.
 1) EER and COP, Energy Saving Classification, is at 220 / 240 V (380 / 415 V) only in accordance with EU directive 2002/31/EC. 2) SEER is calculated in base Eurovent IPLV for SBEM for U1 indoor unit SEER=a[EER25]+b[EER50]+c[EER75]+d[EER100] where EER25, EER50, EER75 and EER100 are the EER measured value at 25%, 50%, 75% and 100% part load for temperatures 20, 25, 30 and 35°C DB, respectively. a, b, c and d are values assigned for an office type. These values are given as a=0,2, b=0,36, c=0,32 and d=0,03. The internal temperatures are taken at 27°C DB and 19°C WB. 3) The annual consumption(ErP) is calculated by formula determined by ErP regulation. 4) Heating capacity is calculated including defrost factor correction. 5) SCOP is calculated in base Eurovent IPLV for SBEM with U1

Standard

Elite

A 5,40 SEER	A 3,80 SCOP	-10°C COOLING MODE	-15°C HEATING MODE	A++ 6,40 SEER	A+ 4,80 SCOP	-15°C COOLING MODE	-20°C HEATING MODE	INVERTER+	DC FAN	R22 RENEWAL R22 RENEWAL R410A	INTERNET CONTROL	CONNECTIVITY BMS	5 YEARS COMPRESSOR WARRANTY
-----------------------	-----------------------	------------------------------	------------------------------	-------------------------	------------------------	------------------------------	------------------------------	------------------	---------------	---	-------------------------	----------------------------	------------------------------------

SEER and SCOP: For KIT-60PFY1E5A and KIT-100PFY1E5A.

SEER and SCOP: For KIT-71PFY1E5A.

INTERNET CONTROL: Optional.

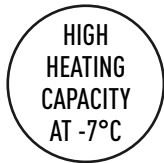

S-100PF1E5A // S-125PF1E5A // S-140PF1E5A



Optional Controller
Wired remote controller
CZ-RTC5



Optional Controller
Timer remote controller
CZ-RTC4



Optional Controller
Wireless remote controller
CZ-RWSK2 + CZ-RWSC3



Optional Controller
Simplified remote controller
CZ-RE2C2

Air Outlet Plenum (without regulation adaptor)	Diameters Model	
	60 & 71	3 x Ø 200
100, 125 & 140	4 x Ø 200	CZ-160DAF2

Air Inlet Plenum	Diameters Model	
	60 & 71	2 x Ø 250
100, 125 & 140	4 x Ø 200	CZ-DUMPA160MF2

Compatible with all Panasonic connectivity solutions. For detailed information go to the Control Systems section.

Elite

Single Phase						Three Phase			
5,0 kW	6,0 kW	7,1 kW	10,0 kW	12,5 kW	14,0 kW	7,1 kW	10,0 kW	12,5 kW	14,0 kW
KIT-50PF1E5A	KIT-60PF1E5A	KIT-71PF1E5A	KIT-100PF1E5A	KIT-125PF1E5A	KIT-140PF1E5A	KIT-71PF1E8A	KIT-100PF1E8A	KIT-125PF1E8A	KIT-140PF1E8A
S-50PF1E5A	S-60PF1E5A	S-71PF1E5A	S-100PF1E5A	S-125PF1E5A	S-140PF1E5A	S-71PF1E8A	S-100PF1E8A	S-125PF1E8A	S-140PF1E8A
U-50PE1E5A	U-60PE1E5A	U-71PE1E5A	U-100PE1E5A	U-125PE1E5A	U-140PE1E5A	U-71PE1E8A	U-100PE1E8A	U-125PE1E8A	U-140PE1E8A
CZ-RTC4	CZ-RTC4	CZ-RTC4	CZ-RTC4	CZ-RTC4	CZ-RTC4	CZ-RTC4	CZ-RTC4	CZ-RTC4	CZ-RTC4
5,0 (1,5 - 5,6)	6,0 (2,5 - 7,1)	7,1 (2,5 - 8,0)	10,0 (3,3 - 12,5)	12,5 (3,3 - 14,0)	14,0 (3,3 - 15,5)	7,1 (3,2 - 8,0)	10,0 (3,3 - 12,5)	12,5 (3,3 - 14,0)	14,0 (3,3 - 15,5)
3,77 (5,58 - 2,80) A	3,90 (4,72 - 3,55) A	3,84 (4,72 - 3,02) A	4,10 (3,93 - 3,38) A	3,50 (3,93 - 3,04) A	3,25 (3,93 - 2,58) A	3,84 (5,0 - 3,02) A	4,10 (3,93 - 3,38) A	3,50 (3,93 - 3,04) A	3,25 (3,93 - 2,58) A
5,7 A+	6,4 A++	6,4 A++	5,8 A+	—	—	6,0 A	5,7 A+	—	—
5,0	6,0	7,1	10,0	—	—	7,1	10,0	—	—
1,350 (0,260 - 2,000)	1,540 (0,530 - 2,000)	1,850 (0,530 - 2,650)	2,440 (0,840 - 3,700)	3,570 (0,840 - 4,600)	4,310 (0,840 - 6,000)	1,850 (0,640 - 2,650)	2,440 (0,840 - 3,700)	3,570 (0,840 - 4,600)	4,310 (0,840 - 6,000)
307	328	388	603	—	—	414	614	—	—
5,6 (1,5 - 6,5)	7,0 (2,0 - 8,0)	8,0 (2,0 - 9,0)	11,2 (4,1 - 14,0)	14,0 (4,1 - 16,0)	16,0 (4,1 - 18,0)	8,0 (2,8 - 9,0)	11,2 (4,1 - 14,0)	14,0 (4,1 - 16,0)	16,0 (4,1 - 18,0)
4,20	6,69	7,52	12,04	13,48	14,24	7,52	12,04	13,48	14,24
3,58	6,56	7,65	11,20	12,38	12,69	7,65	11,20	12,38	12,69
3,73 (6,82 - 2,71) A	3,87 (4,17 - 3,23) A	3,85 (4,17 - 3,10) A	4,31 (4,56 - 3,18) A	4,02 (4,56 - 3,08) A	3,60 (4,56 - 3,05) A	3,85 (4,83 - 3,10) A	4,31 (4,56 - 3,18) A	4,02 (4,56 - 3,08) A	3,60 (4,56 - 3,05) A
3,8 A	3,9 A	4,0 A+	3,8 A	—	—	3,9 A	3,8 A	—	—
4,0	6,0	7,1	10,0	—	—	7,1	10,0	—	—
1,500 (0,220 - 2,400)	1,810 (0,480 - 2,480)	2,080 (0,480 - 2,900)	2,600 (0,900 - 4,400)	3,480 (0,900 - 5,200)	4,440 (0,900 - 5,900)	2,080 (0,580 - 2,900)	2,600 (0,900 - 4,400)	3,480 (0,900 - 5,200)	4,440 (0,900 - 5,900)
1,474	2,154	2,485	3,684	—	—	2,548	3,684	—	—
70 (10 - 150)	70 (10 - 150)	70 (10 - 150)	100 (10 - 150)	100 (10 - 150)	100 (10 - 150)	70 (10 - 150)	100 (10 - 150)	100 (10 - 150)	100 (10 - 150)
960 / 900 / 720	1.260 / 1.140 / 900	1.260 / 1.140 / 900	1.920 / 1.560 / 1.260	2.040 / 1.740 / 1.380	2.160 / 1.920 / 1.500	1.260 / 1.140 / 900	1.920 / 1.560 / 1.260	2.040 / 1.740 / 1.380	2.160 / 1.920 / 1.500
960 / 900 / 720	1.260 / 1.140 / 900	1.260 / 1.140 / 900	1.920 / 1.560 / 1.260	2.040 / 1.740 / 1.380	2.160 / 1.920 / 1.500	1.260 / 1.140 / 900	1.920 / 1.560 / 1.260	2.040 / 1.740 / 1.380	2.160 / 1.920 / 1.500
2,8	3,4	4,2	6,0	7,9	9,0	4,2	6,0	7,9	9,0
34 / 30 / 26	35 / 32 / 26	35 / 32 / 26	38 / 34 / 31	39 / 35 / 32	40 / 36 / 33	35 / 32 / 26	38 / 34 / 31	39 / 35 / 32	40 / 36 / 33
34 / 30 / 26	35 / 32 / 26	35 / 32 / 26	38 / 34 / 31	39 / 35 / 32	40 / 36 / 33	35 / 32 / 26	38 / 34 / 31	39 / 35 / 32	40 / 36 / 33
56 / 52 / 48	57 / 54 / 48	57 / 54 / 48	60 / 56 / 53	61 / 57 / 54	62 / 58 / 55	57 / 54 / 48	60 / 56 / 53	61 / 57 / 54	62 / 58 / 55
56 / 52 / 48	57 / 54 / 48	57 / 54 / 48	60 / 56 / 53	61 / 57 / 54	62 / 58 / 55	57 / 54 / 48	60 / 56 / 53	61 / 57 / 54	62 / 58 / 55
290 x 800 x 700	290 x 1.000 x 700	290 x 1.000 x 700	290 x 1.400 x 700	290 x 1.400 x 700	290 x 1.400 x 700	290 x 1.000 x 700	290 x 1.400 x 700	290 x 1.400 x 700	290 x 1.400 x 700
28	33	33	45	45	45	33	45	45	45
220 / 230 / 240	220 / 230 / 240	220 / 230 / 240	220 / 230 / 240	220 / 230 / 240	220 / 230 / 240	380 / 400 / 415	380 / 400 / 415	380 / 400 / 415	380 / 400 / 415
16	20	20	25	30	16	16	16	16	16
2,5	2,5	2,5	4	6	2,5	2,5	2,5	2,5	2,5
6,10 / 5,85 / 5,60	7,70 / 7,40 / 7,10	8,90 / 8,60 / 8,30	11,0 / 10,6 / 10,3	16,6 / 15,9 / 15,3	20,1 / 19,3 / 18,6	2,75 / 2,65 / 2,60	3,68 / 3,53 / 3,43	5,52 / 5,29 / 5,12	6,69 / 6,42 / 6,18
6,85 / 6,55 / 6,25	8,70 / 8,40 / 8,10	9,90 / 9,50 / 9,20	11,6 / 11,2 / 10,7	16,3 / 15,8 / 15,1	19,9 / 19,1 / 18,4	3,10 / 3,00 / 2,90	3,86 / 3,70 / 3,58	5,44 / 5,26 / 5,05	6,64 / 6,35 / 6,15
1.800 / 2.100	3.600 / 3.600	3.600 / 3.600	6.600 / 5.700	7.800 / 6.600	8.100 / 7.200	3.600 / 3.600	6.600 / 5.700	7.800 / 6.600	8.100 / 7.200
46 / 50	48 / 50	48 / 50	52 / 52	53 / 53	54 / 55	48 / 50	52 / 52	53 / 53	54 / 55
65 / 69	65 / 67	65 / 67	69 / 69	70 / 70	71 / 71	65 / 67	69 / 69	70 / 70	71 / 71
569 x 790 x 285	996 x 940 x 340	996 x 940 x 340	1.416 x 940 x 340	1.416 x 940 x 340	1.416 x 940 x 340	996 x 940 x 340	1.416 x 940 x 340	1.416 x 940 x 340	1.416 x 940 x 340
42	68	69	98	98	98	71	98	98	98
1/4 (6,35)	3/8 (9,52)	3/8 (9,52)	3/8 (9,52)	3/8 (9,52)	3/8 (9,52)	3/8 (9,52)	3/8 (9,52)	3/8 (9,52)	3/8 (9,52)
1/2 (12,7)	5/8 (15,88)	5/8 (15,88)	5/8 (15,88)	5/8 (15,88)	5/8 (15,88)	5/8 (15,88)	5/8 (15,88)	5/8 (15,88)	5/8 (15,88)
1,65	2	2,35	3,4	3,4	3,4	2,35	3,4	3,4	3,4
5 - 40 / 30	5 - 50 / 30	5 - 50 / 30	5 - 75 / 30	5 - 75 / 30	5 - 75 / 30	5 - 50 / 30	5 - 75 / 30	5 - 75 / 30	5 - 75 / 30
30 / 20	30 / 50	30 / 50	30 / 50	30 / 50	30 / 50	30 / 50	30 / 50	30 / 50	30 / 50
-15 / +46	-15 / +46	-15 / +46	-15 / +46	-15 / +46	-15 / +46	-15 / +46	-15 / +46	-15 / +46	-15 / +46
-20 / +24	-20 / +24	-20 / +24	-20 / +24	-20 / +24	-20 / +24	-20 / +24	-20 / +24	-20 / +24	-20 / +24

indoor unit including defrost correction factor. 6) Medium External static pressure setting from factory. 7) The Sound pressure level of the units shows the value measured of a position 1 meter in front of the main body and 1,5 m from the ground. The sound pressure is measured in accordance with Eurovent 6/C/006-97 specification. 8) When installing the outdoor unit at a higher position than the indoor unit. // Recommended fuse for the indoor 3A. For detailed information about ErP, please visit our websites www.aircon.panasonic.eu or www.ptc.panasonic.eu

Accessories



PAN-GRDSD40
Outdoor elevation platform 400 x 900 x 400 mm.



PAN-WTRAY
Tray for condenser water compatible with base ground support



PAN-GRDSE20
Outdoor base ground support for noise and vibration absorption (600 x 95 x 130 mm, 500 kg)



PAN-WPH7: Wind protection shield for U-50PE1E5, U-250PE1E8, U-250PE1E8.
PAN-WPH8: Wind protection shield for U-60PE1E5, U-71PE1E5/R, U-100PE1E5/R, U-125PE1E5/R.
PAN-WPH10: Wind protection shield for U-100PE1E5/R, U-125PE1E5/R, U-140PE1E5/R, U-140PE1E8.



PAN-PACR3
Interfaces to run 3 units on Backup and alternative run.



CZ-90DAF2: Air Outlet Plenum 3 diameters x Ø 200.



U-50PE1E5



U-60PE1E5A
U-71PE1E8A



U-100PE1E5A U-100PE1E8A
U-125PE1E5A U-125PE1E8A
U-140PE1E5A U-140PE1E8A

CEILING
PACi STANDARD AND ELITE
INVERTER+

This range of ceiling mounted units feature a DC fan motor for increased efficiency and reduced operating sound levels. All the units are the same height and depth for a uniform appearance in mixed installations. A knock out is provided to allow for supplementary fresh air for improved air quality.

Technical focus

- Fresh air connection possible (Outside intake duct connection port of 100mm diameter is available on the unit)
- All units just 235 mm high
- Twin rotary compressor dramatically reduces vibration and noise during operation
- DC inverter control
- Large and wide air distribution
- Industry-leading low sound levels
- Twin, Triple and Double-twin split options
- Easy connection and control of external fan or ERV using the connector PAW-FDC on the indoor unit PCB. The external device can be control by the remote control of the Panasonic indoor unit

Standard

		Single Phase				Three Phase			
		6,0 kW	7,1 kW	10,0 kW	12,5 kW	10,0 kW	12,5 kW	14,0 kW	
KIT		KIT-60PTY2E5A	KIT-71PTY2E5A	KIT-100PTY2E5A	KIT-125PTY2E5A	KIT-100PTY2E8A	KIT-125PTY2E8A	KIP-140PTY2E8A	
Indoor		S-60PT2E5A	S-71PT2E5A	S-100PT2E5A	S-125PT2E5A	S-100PT2E5A	S-125PT2E5A	S-140PT2E5A	
Outdoor		U-60PEY1E5	U-71PEY1E5	U-100PEY1E5	U-125PEY1E5	U-100PEY1E8	U-125PEY1E8	U-140PEY1E8	
Timer remote controller		CZ-RTC4	CZ-RTC4	CZ-RTC4	CZ-RTC4	CZ-RTC4	CZ-RTC4	CZ-RTC4	
Cooling capacity	Nominal (Min - Max)	kW	6,0 (2,0 - 7,0)	7,1 (2,2 - 7,7)	10,0 (2,7 - 11,5)	12,5 (3,8 - 13,5)	10,0 (2,7 - 11,5)	12,5 (3,8 - 13,5)	14,0 (3,3 - 15,0)
EER ¹⁾	Nominal (Min - Max)	W/W	3,61 (6,15 - 2,80) A	3,21 (6,15 - 2,73) A	3,01 (5,09 - 2,65) B	3,01 (4,22 - 2,62) B	3,01 (5,09 - 2,65) B	2,98 (3,93 - 2,63) C	
SEER ²⁾	Nominal (Min - Max)	W/W	6,7 A++	6,1 A++	6,1 A++	—	6,0 A+	—	
Pdesign		kW	6,0	7,1	10,0	—	10,0	—	
Power input cooling	Nominal (Min - Max)	kW	1,660 (0,325 - 2,500)	2,210 (0,325 - 2,820)	3,320 (0,530 - 4,340)	4,150 (0,900 - 5,160)	3,320 (0,530 - 4,340)	4,150 (0,900 - 5,160)	4,700 (0,840 - 5,700)
Annual energy consumption (ErP) ³⁾		kWh/a	314	408	574	—	584	—	
Heating capacity	Nominal (Min - Max)	kW	6,0 (1,8 - 7,0)	7,1 (1,8 - 8,1)	10,0 (2,1 - 13,8)	12,5 (3,4 - 15,0)	10,0 (2,1 - 13,8)	12,5 (3,4 - 15,0)	14,0 (4,1 - 16,0)
Heating capacity at -7°C ⁴⁾	Nominal	kW	4,99	5,08	9,97	10,97	9,97	13,35	
Heating capacity at -15°C ⁴⁾	Nominal	kW	4,20	4,37	8,43	9,03	8,43	12,38	
COP ¹⁾	Nominal (Min - Max)	W/W	4,20 A (6,55 - 3,25)	3,90 (6,55 - 3,23) A	3,85 (5,12 - 3,45) A	3,85 (4,66 - 3,41) A	3,85 (5,12 - 3,45) A	3,85 (4,66 - 3,41) A	3,88 (4,56 - 3,07) A
SCOP ⁵⁾	Nominal (Min - Max)	W/W	4,0 A+	4,0 A+	3,9 A	3,40 ⁴⁾	3,9 A	3,40 ⁴⁾	3,52 ⁴⁾
Pdesign at -10°C		kW	6,0	6,0	10,0	—	10,0	—	
Power input heating	Nominal (Min - Max)	kW	1,430 (0,275 - 2,155)	1,820 (0,275 - 2,510)	2,600 (0,410 - 4,000)	3,250 (0,730 - 4,400)	2,600 (0,410 - 4,000)	3,250 (0,730 - 4,400)	3,610 (0,900 - 5,210)
Annual energy consumption (ErP) ³⁾		kWh/a	2.100	2.100	3.590	—	3.590	—	
Indoor unit									
Air volume	Cooling (Hi / Med / Lo)	m³/h	1.200 / 1.020 / 870	1.260 / 1.080 / 930	1.800 / 1.500 / 1.380	2.040 / 1.680 / 1.440	1.800 / 1.500 / 1.380	2.040 / 1.680 / 1.440	2.100 / 1.740 / 1.500
	Heating (Hi / Med / Lo)		1.200 / 1.020 / 870	1.260 / 1.080 / 930	1.800 / 1.500 / 1.380	2.040 / 1.680 / 1.440	1.800 / 1.500 / 1.380	2.040 / 1.680 / 1.440	2.100 / 1.740 / 1.500
Moisture removal volume		l/h	3,4	4,2	6,0	7,9	6,0	7,9	9,0
Sound pressure level ⁶⁾	Cooling (Hi / Med / Lo)	dB(A)	38 / 34 / 30	39 / 35 / 31	42 / 37 / 35	46 / 40 / 36	42 / 37 / 35	46 / 40 / 36	47 / 41 / 37
	Heating (Hi / Med / Lo)	dB(A)	38 / 34 / 30	39 / 35 / 31	42 / 37 / 35	46 / 40 / 36	42 / 37 / 35	46 / 40 / 36	47 / 41 / 37
Sound power level	Cooling (Hi / Med / Lo)	dB	56 / 52 / 48	57 / 53 / 49	60 / 55 / 53	64 / 58 / 54	60 / 55 / 53	64 / 58 / 54	65 / 59 / 55
	Heating (Hi / Med / Lo)	dB	56 / 52 / 48	57 / 53 / 49	60 / 55 / 53	64 / 58 / 54	60 / 55 / 53	64 / 58 / 54	65 / 59 / 55
Dimensions	H x W x D	mm	235 x 1.275 x 690	235 x 1.275 x 690	235 x 1.590 x 690	235 x 1.590 x 690	235 x 1.590 x 690	235 x 1.590 x 690	235 x 1.590 x 690
Net weight		kg	33	33	40	40	40	40	40
Outdoor unit									
Power source		V	220 / 230 / 240	220 / 230 / 240	220 / 230 / 240	220 / 230 / 240	380 / 400 / 415	380 / 400 / 415	380 / 400 / 415
Recommended fuse		A	20	20	25	30	16	16	16
Connection		mm²	2,5	2,5	4	6	2,5	2,5	2,5
Current	Cooling	A	8,05 / 7,70 / 7,40	10,8 / 10,3 / 9,85	15,6 / 15,0 / 14,4	19,7 / 18,9 / 18,1	5,30 / 5,05 / 4,85	6,50 / 6,20 / 6,00	7,40 / 7,00 / 6,80
	Heating	A	6,90 / 6,60 / 6,30	8,75 / 8,35 / 8,00	11,9 / 11,5 / 11,1	15,2 / 14,6 / 13,9	4,10 / 3,90 / 3,75	5,10 / 4,80 / 4,65	5,65 / 5,35 / 5,15
Air volume	Cooling / Heating	m³/h	1.800 / 2.100	2.340 / 2.340	4.560 / 4.020	4.800 / 4.380	4.560 / 4.020	4.800 / 4.380	8.100 / 7.200
Sound pressure level	Cooling / Heating (Hi)	dB(A)	46 / 50	50 / 52	54 / 54	56 / 56	54 / 54	56 / 56	54 / 53
Sound power level	Cooling / Heating (Hi)	dB	65 / 69	70 / 70	70 / 70	73 / 73	70 / 70	73 / 73	71 / 70
Dimensions	H x W x D	mm	569 x 790 x 285	569 x 790 x 285	996 x 940 x 340	996 x 940 x 340	996 x 940 x 340	996 x 940 x 340	1.416 x 940 x 340
Net weight		kg	42	42	73	85	73	85	98
Piping connections	Liquid pipe	Inch (mm)	3/8 (9,52)	3/8 (9,52)	3/8 (9,52)	3/8 (9,52)	3/8 (9,52)	3/8 (9,52)	3/8 (9,52)
	Gas pipe	Inch (mm)	5/8 (15,88)	5/8 (15,88)	5/8 (15,88)	5/8 (15,88)	5/8 (15,88)	5/8 (15,88)	5/8 (15,88)
Refrigerant loading	R410A	kg	1,70	1,70	2,60	3,20	2,60	3,20	3,40
Piping length / Elevation difference (in/out) ⁷⁾		m	5 - 50 / 30	5 - 50 / 30	5 - 50 / 30	5 - 50 / 30	5 - 50 / 30	5 - 50 / 30	5 - 50 / 30
Pipe length for additional gas / Additional gas amount		m / g/m	20 / 40	20 / 40	30 / 50	30 / 50	30 / 50	30 / 50	30 / 50
Operating range	Cooling Min / Max	°C	-10 / +43	-10 / +43	-10 / +43	-10 / +43	-10 / +43	-10 / +43	-10 / +43
	Heating Min / Max	°C	-15 / +24	-15 / +24	-15 / +24	-15 / +24	-15 / +24	-15 / +24	-15 / +24

Rating Conditions: Cooling Indoor 27°C DB / 19°C WB. Cooling Outdoor 35°C DB / 24°C WB. Heating Indoor 20°C DB. Heating Outdoor 7°C DB / 6°C WB. (DB: Dry Bulb; WB: Wet Bulb). // Specifications subject to change without notice.
 1) EER and COP, Energy Saving Classification, is at 220 / 240 V (380 / 415 V) only in accordance with EU directive 2002/31/EC. 2) SEER is calculated in base Eurovent IPLV for SBEM for U1 indoor unit SEER=a(EER25)+c(EER50)+d(EER75)+e(EER100) where EER25, EER50, EER75 and EER100 are the EER measured value at 25%, 50%, 75% and 100% part load for temperatures 20, 25, 30 and 35°C DB, respectively. a, b, c and d are values assigned for an office type. These values are given as a=0,2, b=0,36, c=0,32 and d=0,03. The internet temperatures are taken at 27°C DB and 19°C WB. 3) The annual consumption(ErP) is calculated by formula determined by ErP regulation. 4) Heating capacity is calculated including defrost factor correction. 5) SCOP is calculated in base Eurovent IPLV for SBEM with U1

Standard

Elite

A++ 6,10 SEER	A 3,90 SCOP	-10°C COOLING MODE	-15°C HEATING MODE	A++ 6,80 SEER	A+ 4,10 SCOP	-15°C COOLING MODE	-20°C HEATING MODE	INVERTER+	R22 RENEWAL R22 R410A	INTERNET CONTROL	BMS CONNECTIVITY	5 YEARS COMPRESSOR WARRANTY
-------------------------	-----------------------	------------------------------	------------------------------	-------------------------	------------------------	------------------------------	------------------------------	------------------	---------------------------------	-------------------------	-------------------------	------------------------------------

SEER and SCOP: For KIT-100PTY2E5A.

SEER and SCOP: For KIT-60PTY2E5A.

INTERNET CONTROL: Optional.

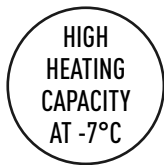

Optional Controller
Wired remote controller
CZ-RTC5



Optional Controller
Timer remote controller
CZ-RTC4



Optional Controller
Wireless remote controller
CZ-RWST3N



Optional Controller
Simplified remote controller
CZ-RE2C2



Compatible with all Panasonic connectivity solutions. For detailed information go to the Control Systems section.

Elite

Single Phase						Three Phase			
5,0 kW	6,0 kW	7,1 kW	10,0 kW	12,5 kW	14,0 kW	7,1 kW	10,0 kW	12,5 kW	14,0 kW
KIT-50PT2E5A	KIT-60PT2E5A	KIT-71PT2E5A	KIT-100PT2E5A	KIT-125PT2E5A	KIT-140PT2E5A	KIT-71PT2E8A	KIT-100PT2E8A	KIT-125PT2E8A	KIT-140PT2E8A
S-50PT2E5A	S-60PT2E5A	S-71PT2E5A	S-100PT2E5A	S-125PT2E5A	S-140PT2E5A	S-71PT2E8A	S-100PT2E8A	S-125PT2E8A	S-140PT2E8A
U-50PE1E5	U-60PE1E5A	U-71PE1E5A	U-100PE1E5A	U-125PE1E5A	U-140PE1E5A	U-71PE1E8A	U-100PE1E8A	U-125PE1E8A	U-140PE1E8A
CZ-RTC4	CZ-RTC4	CZ-RTC4	CZ-RTC4	CZ-RTC4	CZ-RTC4	CZ-RTC4	CZ-RTC4	CZ-RTC4	CZ-RTC4
5,0 (1,5 - 5,6)	6,0 (2,5 - 7,1)	7,1 (2,5 - 8,0)	10,0 (3,3 - 12,5)	12,5 (3,3 - 14,0)	14,0 (3,3 - 15,0)	7,1 (2,5 - 8,0)	10,0 (3,3 - 12,5)	12,5 (3,3 - 14,0)	14,0 (3,3 - 15,0)
3,62 (5,77 - 2,73) A	4,03 (5,56 - 3,53) A	3,68 (5,56 - 2,88) A	3,95 (3,93 - 3,25) A	3,35 (3,93 - 2,88) A	3,01 (3,93 - 2,65) B	3,68 (5,56 - 2,88) A	3,95 (3,93 - 3,25) A	3,35 (3,93 - 2,88) A	3,01 (3,93 - 2,65) B
6,4 A+++	6,8 A+++	6,2 A+++	6,7 A+++	—	—	5,9 A+	6,6 A+++	—	—
5,0	6,0	7,1	10,0	—	—	7,1	10,0	—	—
1,380 (0,260 - 2,050)	1,490 (0,450 - 2,010)	1,930 (0,450 - 2,780)	2,530 (0,840 - 3,850)	3,730 (0,840 - 4,860)	4,650 (0,840 - 5,650)	1,930 (0,450 - 2,780)	2,530 (0,840 - 3,850)	3,730 (0,840 - 4,860)	4,650 (0,840 - 5,650)
273	309	965	523	—	—	421	531	—	—
5,6 (1,5 - 6,5)	7,0 (2,0 - 8,0)	8,0 (2,0 - 9,0)	11,2 (4,1 - 14,0)	14,0 (4,1 - 16,0)	16,0 (4,1 - 18,0)	8,0 (2,0 - 9,0)	11,2 (4,1 - 14,0)	14,0 (4,1 - 16,0)	16,0 (4,1 - 18,0)
4,20	6,69	7,52	12,04	13,48	14,24	7,52	12,04	13,48	14,24
3,58	6,56	7,65	11,20	12,38	12,69	7,65	11,20	12,38	12,69
3,97 (6,82 - 2,83) A	4,02 (5,00 - 3,23) A	4,15 (5,00 - 3,10) A	4,31 (4,56 - 3,18) A	3,99 (4,56 - 3,07) A	3,67 (4,56 - 3,04) A	4,15 (5,00 - 3,10) A	4,31 (4,56 - 3,18) A	3,99 (4,56 - 3,07) A	3,67 (4,56 - 3,04) A
4,0 A	4,1 A+	4,0 A+	4,3 A+	3,63 ⁴⁾	3,41 ⁴⁾	4,0 A+	4,3 A+	3,63 ⁴⁾	3,41 ⁴⁾
4,0	6,0	7,1	10,0	—	—	7,1	10,0	—	—
1,410 (0,220 - 2,300)	1,740 (0,400 - 2,480)	1,930 (0,400 - 2,900)	2,600 (0,900 - 4,400)	3,510 (0,900 - 5,210)	4,360 (0,900 - 5,930)	1,930 (0,400 - 2,900)	2,600 (0,900 - 4,400)	3,510 (0,900 - 5,210)	4,360 (0,900 - 5,930)
1.400	2.049	2.485	3.256	—	—	2.485	3.256	—	—
900 / 750 / 630	1.200 / 1.020 / 870	1.260 / 1.080 / 930	1.800 / 1.500 / 1.380	2.040 / 1.680 / 1.440	2.100 / 1.740 / 1.500	1.260 / 1.080 / 930	1.800 / 1.500 / 1.380	2.040 / 1.680 / 1.440	2.100 / 1.740 / 1.500
2,8	3,4	4,2	6,0	7,9	9,0	4,2	6,0	7,9	9,0
37 / 33 / 29	38 / 34 / 30	39 / 35 / 31	42 / 37 / 35	46 / 40 / 36	47 / 41 / 37	39 / 35 / 31	42 / 37 / 35	46 / 40 / 36	47 / 41 / 37
37 / 33 / 29	38 / 34 / 30	39 / 35 / 31	42 / 37 / 35	46 / 40 / 36	47 / 41 / 37	39 / 35 / 31	42 / 37 / 35	46 / 40 / 36	47 / 41 / 37
55 / 51 / 47	56 / 52 / 48	57 / 53 / 49	60 / 55 / 53	64 / 58 / 54	65 / 59 / 55	57 / 53 / 49	60 / 55 / 53	64 / 58 / 54	65 / 59 / 55
55 / 51 / 47	56 / 52 / 48	57 / 53 / 49	60 / 55 / 53	64 / 58 / 54	65 / 59 / 55	57 / 53 / 49	60 / 55 / 53	64 / 58 / 54	65 / 59 / 55
235 x 960 x 690	235 x 1.275 x 690	235 x 1.275 x 690	235 x 1.590 x 690	235 x 1.590 x 690	235 x 1.590 x 690	235 x 1.275 x 690	235 x 1.590 x 690	235 x 1.590 x 690	235 x 1.590 x 690
27	33	33	40	40	40	33	40	40	40
220 / 230 / 240	220 / 230 / 240	220 / 230 / 240	220 / 230 / 240	220 / 230 / 240	220 / 230 / 240	380 / 400 / 415	380 / 400 / 415	380 / 400 / 415	380 / 400 / 415
16	20	20	25	30	16	16	16	16	16
2,5	2,5	2,5	4	6	2,5	2,5	2,5	2,5	2,5
6,55 / 6,25 / 6,00	7,15 / 6,90 / 6,70	9,00 / 8,70 / 8,40	11,5 / 11,1 / 10,6	17,0 / 16,4 / 15,8	21,2 / 20,5 / 19,8	3,00 / 2,90 / 2,80	3,95 / 3,75 / 3,65	5,85 / 5,55 / 5,35	7,30 / 6,95 / 6,70
6,70 / 6,40 / 6,15	8,10 / 7,80 / 7,60	8,90 / 8,60 / 8,30	11,8 / 11,4 / 11,0	16,0 / 15,4 / 14,9	19,8 / 19,2 / 18,5	3,00 / 2,90 / 2,80	4,05 / 3,85 / 3,75	5,50 / 5,20 / 5,05	6,85 / 6,50 / 6,25
1.800 / 2.100	3.600 / 3.600	3.600 / 3.600	6.600 / 5.700	7.800 / 6.600	8.100 / 7.200	3.600 / 3.600	6.600 / 5.700	7.800 / 6.600	8.100 / 7.200
46 / 50	48 / 50	48 / 50	52 / 52	53 / 53	54 / 55	48 / 50	52 / 52	53 / 53	54 / 55
65 / 69	65 / 67	65 / 67	69 / 69	70 / 70	71 / 71	65 / 67	69 / 69	70 / 70	71 / 71
569 x 790 x 285	996 x 940 x 340	996 x 940 x 340	1.416 x 940 x 340	1.416 x 940 x 340	1.416 x 940 x 340	996 x 940 x 340	1.416 x 940 x 340	1.416 x 940 x 340	1.416 x 940 x 340
42	68	69	98	98	98	71	98	98	98
1/4 (6,35)	3/8 (9,52)	3/8 (9,52)	3/8 (9,52)	3/8 (9,52)	3/8 (9,52)	3/8 (9,52)	3/8 (9,52)	3/8 (9,52)	3/8 (9,52)
1/2 (12,7)	5/8 (15,88)	5/8 (15,88)	5/8 (15,88)	5/8 (15,88)	5/8 (15,88)	5/8 (15,88)	5/8 (15,88)	5/8 (15,88)	5/8 (15,88)
1,65	2,00	2,35	3,40	3,40	3,40	2,35	3,40	3,40	3,40
5 - 40 / 30	5 - 50 / 30	5 - 50 / 30	5 - 75 / 30	5 - 75 / 30	5 - 75 / 30	5 - 50 / 30	5 - 75 / 30	5 - 75 / 30	5 - 75 / 30
30 / 20	30 / 50	30 / 50	30 / 50	30 / 50	30 / 50	30 / 50	30 / 50	30 / 50	30 / 50
-15 / +46	-15 / +46	-15 / +46	-15 / +46	-15 / +46	-15 / +46	-15 / +46	-15 / +46	-15 / +46	-15 / +46
-20 / +24	-20 / +24	-20 / +24	-20 / +24	-20 / +24	-20 / +24	-20 / +24	-20 / +24	-20 / +24	-20 / +24

indoor unit including defrost correction factor. 6) The Sound pressure level of the units shows the value measured of a position 1 meter in front of the main body and 1,5 m from the ground. The sound pressure is measured in accordance with Eurovent 6/C/006-97 specification. 7) When installing the outdoor unit at a higher position than the indoor unit. // Recommended fuse for the indoor 3A. For detailed information about ErP, please visit our websites www.aircon.panasonic.eu or www.ptc.panasonic.eu

Accessories



PANH-GRDST40
Outdoor elevation platform 400 x 900 x 400 mm.



PANH-WTRAY
Tray for condenser water compatible with base ground support



PANH-GRDSE20
Outdoor base ground support for noise and vibration absorption (600 x 95 x 130 mm, 500 kg)



PANH-WPH7: Wind protection shield for U-50PE1E5, U-71PE1E5/R, U-100PE1E5/R, U-125PE1E5/R, U-140PE1E5/R.
PANH-WPH8: Wind protection shield for U-200PE1E8, U-250PE1E8.
PANH-WPH9: Wind protection shield for U-60PE1E5, U-71PE1E5/R, U-100PE1E5/R, U-125PE1E5/R.
PANH-WPH10: Wind protection shield for U-100PE1E5/R, U-125PE1E5/R, U-140PE1E5/R, U-140PE1E8.



PANH-PACR3
Interfaces to run 3 units on Backup and alternative run.



U-60PE1E5
U-100PE1E5
U-50PE1E5



U-100PE1E5
U-125PE1E5
U-140PE1E8



U-60PE1E5A
U-71PE1E8A
U-140PE1E8
U-100PE1E8A

HIGH STATIC PRESSURE HIDE AWAY 20-25kW BIG PACi INVERTER+

Panasonic breaks new ground in offering high performance and power in a small space. The 20-25 kW from Panasonic is ideally suited for large retail applications and other large areas not needing the higher capacities of VRF systems. The lightweight and compact design enables easier installation in any commercial space. The twin fan system saves valuable footprint compared to traditional 20-25kW systems which are larger and therefore require more space.

			Three Phase	
			20,0 kW	25,0 kW
KIT			KIT-200PE2E5	KIT-250PE2E5
Indoor			S-200PE2E5	S-250PE2E5
Outdoor			U-200PE1E8	U-250PE1E8
Timer remote controller			CZ-RTC4	CZ-RTC4
Cooling capacity	Nominal (Min - Max)	kW	19,5 (6,0 - 22,4)	25,0 (6,0 - 22,4)
EER ¹⁾	Nominal	W/W	3,04 B	3,04 B
SEER ²⁾		W/W		
Power input cooling	Nominal	kW	6,42	6,42
Running amperes		A	—	—
Heating capacity	Nominal (Min - Max)	kW	22,4 (6,0 - 25,0)	28,0 (6,0 - 25,0)
Heating capacity at -7°C ³⁾	Nominal	kW	17,34	21,85
Heating capacity at -15°C ³⁾	Nominal	kW	16,00	20,16
COP ¹⁾	Nominal	W/W	3,54 B	3,54 B
SCOP ⁴⁾		W/W		
Power input heating	Nominal	kW	6,32	6,32
Running amperes		A	—	—
Indoor unit				
Power source		V / ph / Hz	220 - 230 - 240 / 1 / 50	220 - 230 - 240 / 1 / 50
External static pressure at shipment (with booster cable)		Pa	60	72
Air volume	Hi / Med / Lo	m ³ /h	3.360 / 3.060 / 2.640	4.320 / 3.780 / 3.180
Moisture removal volume	Cooling	l/h	—	—
Sound pressure level ⁵⁾	Hi / Med / Lo	dB(A)	43 / 41 / 38	47 / 45 / 42
Sound power level	Hi / Med / Lo	dB	75 / 73 / 70	79 / 77 / 74
Dimensions	H x W x D	mm	479 x 1.453 x 1.205	479 x 1.453 x 1.205
Net weight		kg	100	104
Outdoor unit				
Power source		V / ph / Hz	380 / 400 / 415 / 3+N / 50	380 / 400 / 415 / 3+N / 50
Recommended fuse		A	15	20
Air volume	Cooling / Heating	m ³ /h	7.740	7.740
Sound pressure level ⁵⁾	Cooling / Heating (Hi)	dB(A)	57 / 57	57 / 57
Sound power level		dB	72	72
Dimensions ⁶⁾	H x W x D	mm	1.526 x 940 x 340	1.526 x 940 x 340
Net weight		kg	118	118
Piping connections	Liquid pipe	Inch (mm)	3/8 (9,52)	1/2 (12,7)
	Gas pipe	Inch (mm)	1 (25,4)	1 (25,4)
Refrigerant loading		kg	5,3	5,3
Piping length / Elevation difference (in/out) ⁷⁾		m	5 - 100 / 30	5 - 100 / 30
Pipe length for additional gas / Additional gas amount		m / g/m	30 / 40	30 / 40
Operating range	Cooling Min / Max	°C	-15 / +46	-15 / +46
	Heating Min / Max	°C	-20 / +24	-20 / +24

Rating Conditions: Cooling Indoor 27°C DB / 19°C WB. Cooling Outdoor 35°C DB / 24°C WB. Heating Indoor 20°C DB. Heating Outdoor 7°C DB / 6°C WB. (DB: Dry Bulb; WB: Wet Bulb)

1) EER and COP, Energy Saving Classification, is at 220 / 240 V (380 / 415 V) only in accordance with EU directive 2002/31/EC. 2) SEER is calculated in base Eurovent IPLV for SBEM for U1 indoor unit SEER=a(EER25)+b(EER50)+c(EER75)+d(EER100) where EER25, EER50, EER75 and EER100 are the EER measured value at 25%, 50%, 75% and 100% part load for temperatures 20, 25, 30 and 35°C DB, respectively. a, b, c and d are values assigned for an office type. These values are given as a=0,2, b=0,36, c=0,32 and d=0,03. The internal temperatures are taken at 27°C DB and 19°C WB. 3) Heating capacity is calculated including defrost factor correction. 4) SCOP is calculated in base Eurovent IPLV for SBEM with U1 indoor unit including defrost correction factor. 5) The sound pressure Level of the units shows the value measured of a position 1 meter in front of the main body and 1,5 m from the ground. The sound pressure is measured in accordance with Eurovent 6/C/006-97 specification. 6) Add 100 mm for indoor unit or 70 mm for outdoor unit for piping port. 7) When installing the outdoor unit at a higher position than the indoor unit.

Specifications subject to change without notice.

For detailed information about ErP, please visit our websites www.aircon.panasonic.eu or www.ptc.panasonic.eu



INTERNET CONTROL: Optional.

HIGH HEATING CAPACITY AT -7°C



Optional Controller
Wired remote controller
CZ-RTC5



Optional Controller
Timer remote controller
CZ-RTC4



Optional Controller
Wireless remote controller
CZ-RWSK2 + CZ-RWSC3



Optional Controller
Simplified remote controller
CZ-RE2C2



Compatible with all Panasonic connectivity solutions. For detailed information go to the Control Systems section.

Technical focus

- High efficiency inverter system
- Cooling with low outdoor temperatures (down to -15°C)
- Maximum pipe length 100 m (more than 40% longer than other split systems)
- Multifunctional wireless remote control with built-in temperature control
- Fresh air supply for improved air quality

Features

Energy efficiency and ecology

- Maximum efficiency Inverter system
- R410A environmentally friendly refrigerant gas

Comfort

- Cooling with low outdoor temperatures (down to -15°C)
- Heating with low outdoor temperatures (down to -20°C)
- Selection of temperature sensor at indoor unit or wired remote control

Easy of use

- Weekly On/Off timer (6 settings per day and 42 per week)
- Selection of wired / Wireless and simplified wired remote controller

Easy installation and maintenance

- High static pressure units ideal for shops and offices

System example

An inspection port (450 x 450 mm or more) is required at the lower side of the indoor unit body. Distributor (field supply).

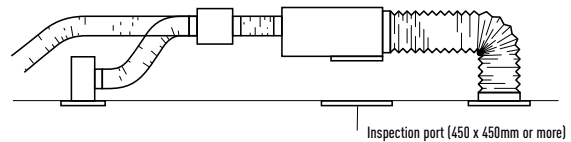

Plenums

Air Outlet Plenum (suitable for rigid + flexible duct)

	N. of exits with diameters	Model
S-250PE1E8	1 x 500 mm	CZ-TREMIESPW706
S-200PE1E8A	1 x 450 mm	CZ-TREMIESPW705

Accessories



PAN-GRDSTD4
Outdoor elevation platform 400 x 900 x 400 mm.



PAN-WTRAY
Tray for condenser water compatible with base ground support



PAN-GRDBSE20
Outdoor base ground support for noise and vibration absorption (600 x 95 x 130 mm, 500 kg)



PAN-PACR3
Interfaces to run 3 units on Backup and alternative run.

NEW



U-200PE1E8
U-250PE1E8



PACi Single, Twin, Triple and Double-Twin System

With this system, a single outdoor unit can split capacity for up to 4 indoor areas simultaneously. This makes the system particularly apt for common areas. It reduces noise concentration and enables the same temperature to be reached around the room. A mix of indoor units can be installed (wall, cassette, duct, ceiling) in one system.

PACi Standard Single and Twin System from 10,0 to 12,5 kW

Up to 2 indoor units connectable on the same outdoor. Panasonic's PACi units can be installed as single and twin systems. The indoor units can be combined following the selection table. The operation will always be simultaneous. All the indoor units will work with the same settings.

PACi Elite Twin, Triple and Double-Twin System from 7,1 to 14,0 kW

Up to 4 indoor units can be connected to the same outdoor unit. Panasonic's PACi units 71, 100, 125 and 140 can be installed as twin, triple and double-twin systems. The indoor units can be combined as per the selection table. The operation will always be simultaneous. All the indoor units will work with the same settings.

Big PACi Elite Twin, Triple and Double-Twin System from 20,0 to 25,0 kW

Up to 4 indoor units can be connected to the same outdoor unit. Panasonic's PACi units 200 and 250 can be installed as twin, triple and double-twin systems. The indoor units can be combined as per the selection table. The operation will always be simultaneous. All the indoor units will work with the same settings.

Indoor unit capacities

Capacity	Wall	4 Way 60x60 Cassette	4 Way 90x90 Cassette	Low Static Pressure Hide Away	High Static Pressure Hide Away	Ceiling
3,6 kW	S-36PK1E5A	S-36PY2E5A	S-36PU1E5A	S-36PN1E5A	S-36PF1E5A	S-36PT2E5A
4,5 kW	S-45PK1E5A	S-45PY2E5A	S-45PU1E5A	S-45PN1E5A	S-45PF1E5A	S-45PT2E5A
5,0 kW	S-50PK1E5A	S-50PY2E5A	S-50PU1E5A	S-50PN1E5A	S-50PF1E5A	S-50PT2E5A
6,0 kW	S-60PK1E5A		S-60PU1E5A	S-60PN1E5A	S-60PF1E5A	S-60PT2E5A
7,1 kW	S-71PK1E5A		S-71PU1E5A	S-71PN1E5A	S-71PF1E5A	S-71PT2E5A
10,0 kW	S-100PK1E5A		S-100PU1E5A	S-100PN1E5A	S-100PF1E5A	S-100PT2E5A
12,5 kW			S-125PU1E5A	S-125PN1E5A	S-125PF1E5A	S-125PT2E5A

Outdoor unit capacities

Capacity	PACi Standard Single and Twin System	PACi Elite Twin, Triple and Double-Twin System from 7,1 to 14,0 kW	PACi Elite Twin, Triple and Double-Twin System from 20,0 to 25,0 kW
7,1 kW	U-71PEY1E5	U-71PE1E5A // U-71PE1E8A	
10,0 kW	U-100PEY1E5 // U-100PEY1E8		U-100PE1E5A // U-100PE1E8A
12,5 kW	U-125PEY1E5 // U-125PEY1E8		U-125PE1E5A // U-125PE1E8A
14,0 kW	U-140PEY1E8		U-140PE1E5A // U-140PE1E8A
20,0 kW			U-200PE1E8
25,0 kW			U-250PE1E8

U-__1E5 Single Phase // U-__1E8 Three Phase

PACi Standard Single/Simultaneous operation system combinations

kW Indoor	Outdoor	7,1	10,0	12,5	14,0
3,6	Twin	U-71 S-36 S-36			
5,0			Twin	U-100 S-50 S-50	
6,0				Twin	U-125 S-60 S-60
7,1	Single ¹	U-71 S-71			Twin
10,0			Single ¹	U-100 S-100	U-140 S-71 S-71
12,5				Single ¹	U-125 S-125
14,0					Single ¹

PACi Elite from 7,1 to 14,0 kW Single/Simultaneous operation system combinations

kW Indoor	Outdoor	7,1	10,0	12,5	14,0
3,6	Twin	U-71 S-36 S-36	Triple	Double-Twin	
4,5				Triple	
5,0			Twin		Triple
6,0				Twin	
7,1	Single ¹	U-71 S-71			Twin
10,0			Single ¹	U-100 S-100	
12,5				Single ¹	U-125 S-125
14,0					Single ¹

PACi Elite from 20,0 to 25,0 kW Single/Simultaneous operation system combinations

kW Indoor	Outdoor	20,0	25,0
5,0	Double-Twin	U-200 S-50 S-50 S-50 S-50	
6,0			Double-Twin
7,1	Triple	U-200 S-71 S-71 S-71	
10,0	Twin	U-200 S-100 S-100	
12,5			Twin
20,0	Single ¹	U-200 S-200	
25,0			Single ¹

1. PACi 1x1 Kit solution.

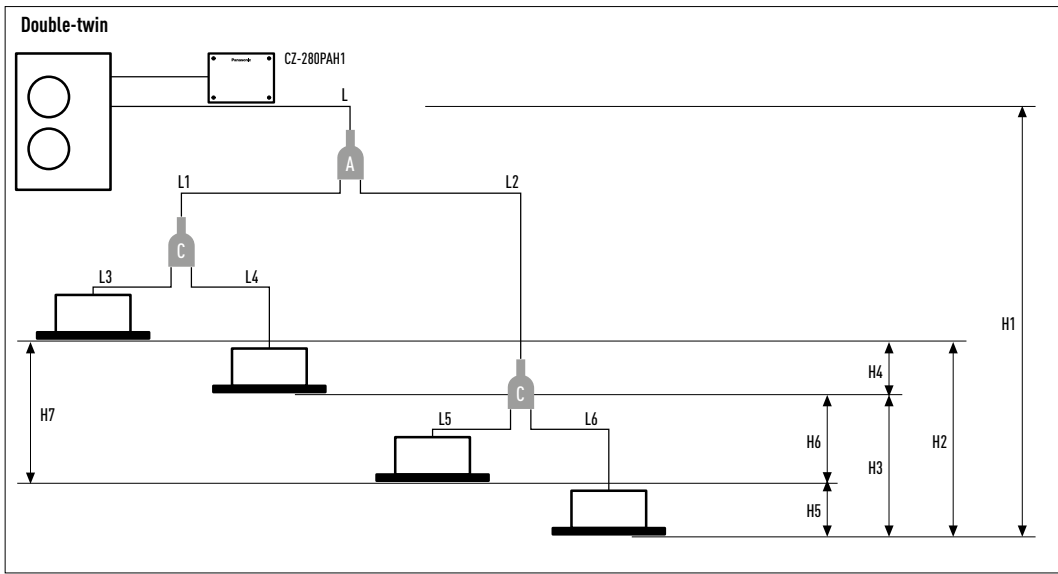
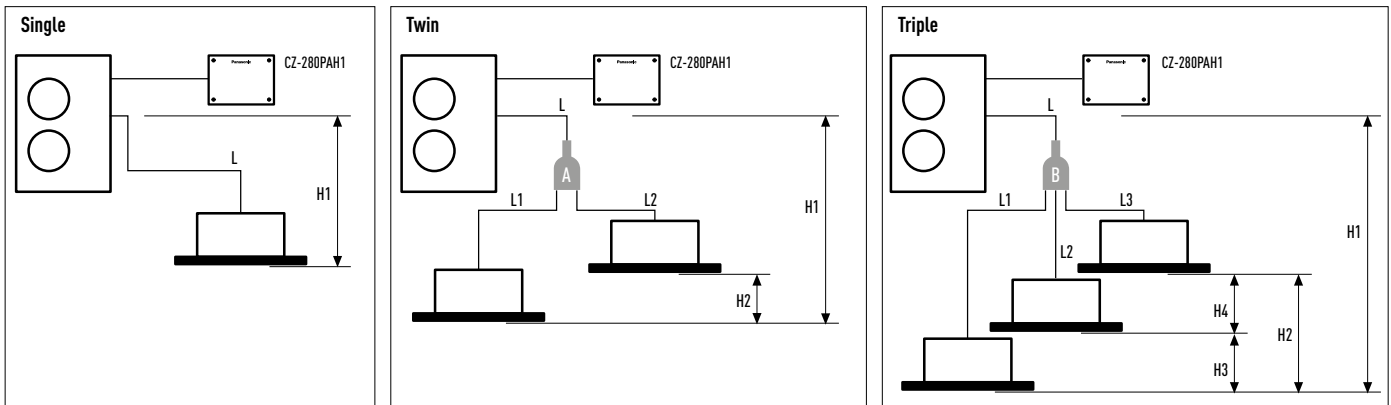

PACi Standard Twin System
 Joint distribution (sold separately)
 A= CZ-P224BK2BM

PACi Elite Twin, Triple and Double-Twin System from 7,1 to 14,0 kW
 Joint distribution (sold separately)
 A= CZ-P224BK2BM
 B= CZ-P3HPC2BM
 C= CZ-P224BK2BM

PACi Elite Twin, Triple and Double-Twin System from 20,0 to 25,0 kW
 Joint distribution (sold separately)
 A= CZ-P680BK2BM
 B= CZ-P3HPC2BM
 C= CZ-P224BK2BM

Twin System	PACi Standard Single and Twin System			PACi Elite Twin, Triple and Double-Twin System from 7,1 to 25 kW					
	Indoor unit combinations (see examples above)		Equivalent lengths and height differences (m) for outdoor unit sizes...	Indoor unit combinations (see examples above)				Equivalent lengths and height differences (m) for outdoor unit sizes from 7,1 to 14,0 kW	Equivalent lengths and height differences (m) for outdoor unit sizes from 20,0 to 25,0 kW
Single	Twin	Single		Twin	Triple	Double-Twin			
Total pipe length	L	L + L1 + L2	≤ 50 m	L	L + L1 + L2	L + L1 + L2 + L3	L + L1 + L2 + L3 + L4 + L5 + L6	U-60/U-71: ≤ 50 m U-100/125/140: ≤ 75 m	≤ 100 m
Maximum pipe length from outdoor unit to most distant indoor unit	-	-	-	L + L1 or L + L2	L + L1 or L + L2 or L + L3	L + L1 or L + L2 or L + L3	L + L1 + L3 or L + L1 + L4 or L + L2 + L5 or L + L2 + L6	-	≤ 100 m
Maximum branch pipe length	-	L1 L2	≤ 15	L1 or L2	L1 or L2 or L3	L1 or L2 or L3	L1 + L3 or L1 + L4 or L2 + L5 or L2 + L6	≤ 15 m	≤ 20 m
Maximum branch pipe length differences	-	L1 > L2 L1 - L2	≤ 10	L1 > L2: L1 - L2	L1 > L2 > L3: L1 - L2 L2 - L3 L1 - L3	L1 > L2 > L3: L1 - L2 L2 - L3 L1 - L3	L2 + L6 (Max.) L1 + L3 (Min.): (L2 + L6) - (L1 + L3)	≤ 10 m	≤ 10 m
Maximum pipe length differences after first branch (Double-Twin)	-	-	-	-	-	-	L2 > L1: L2 - L1	≤ 10 m	≤ 10 m
Maximum pipe length differences after second branch (Double-Twin)	-	-	-	-	-	-	L4 > L3: L4 - L3 L6 > L5: L6 - L5	≤ 10 m	≤ 10 m
Height difference (outdoor unit located higher)	H1	H1	≤ 30	H1	H1	H1	H1	≤ 30 m	≤ 30 m
Height difference (outdoor unit located lower)	H1	H1	≤ 15	H1	H1	H1	H1	≤ 15 m	≤ 15 m
Height difference between indoor units	-	H2	≤ 0.5	-	H2	H2 or H3 or H4	H2 or H3 or H4 or H5 or H6	≤ 0.5 m	≤ 0.5 m

Twin System	PACi Standard Single and Twin System				PACi Elite Twin, Triple and Double-Twin System from 7,1 to 14,0 kW						PACi Elite Twin, Triple and Double-Twin System from 20,0 to 25,0 kW				
	Outdoor unit main pipe diameter (L)		Indoor unit connection tube (L1, L2)		Outdoor unit main pipe diameter (L)	Indoor unit connection pipe diameter (L1, L2, L3, L4) (mm)					Outdoor unit main pipe diameter (L) (mm)		Double-Twin distribution pipe (L1, L2) ¹⁾	Indoor unit connection pipe diameter	
Unit type capacity	100	125	50	60	71 - 140	36	45	50	60	71	200	250	100 - 125	50	60 - 125
Liquid pipe (mm)	Ø 9,52	Ø 12,7	Ø 6,35	Ø 9,52	Ø 9,52	Ø 6,35	Ø 6,35	Ø 6,35	Ø 9,52	Ø 9,52	Ø 9,52	Ø 12,7	Ø 9,52	Ø 6,35	Ø 9,52
Gas pipe (mm)	Ø 15,88	Ø 15,88	Ø 12,7	Ø 15,88	Ø 15,88	Ø 12,70	Ø 12,70	Ø 12,70	Ø 15,88	Ø 15,88	Ø 25,4	Ø 25,4	Ø 15,88	Ø 12,7	Ø 15,88
Additional gas amount (g/m)	50	50	20	50	50	20	20	20	50	50	40	80	40	20	40

1. Total capacity of indoor unit connected after the branch

Refrigerant charging: For the twin connection, the amount of refrigerant required for pipe length 30 m has been included in this unit at the factory while that required for pipe length 20 m has been included for the Triple / Double-Twin connections. No Additional gas amount is required for the first 30 m pipe length in the case of the twin connection and for the first 20 m in the case of the Triple / Double-Twin connections. The amount of included refrigerant for each model is listed on NAMA PLATE. Make Additional gas amounts by adding up pipe length in an order of main (L branch pipe), (L1, L2, L3 wide diameter) and then selecting the amount of refrigerant corresponding to the remaining (after 30 m for the Twin connection and after 20 m for the Triple / Double-Twin connections) liquid side pipe diameter and pipe length from the below table.



Optional Controller.
Wired remote controller
CZ-RTC5



Optional Controller.
Timer remote controller
CZ-RTC4



Optional Controller.
Wireless remote controller
Various type.



Optional Controller.
Simplified remote controller
CZ-REZC2

Compatible with all Panasonic connectivity solutions. For detailed information go to the Control Systems section.

Compatible Indoor Units		3,6 kW	4,5 kW	5,0 kW	6,0 kW	7,1 kW	10,0 kW	12,5 kW	
Capacity for all indoor units	Cooling	kW	3,6	4,5	5,0	6,0	7,1	10,0	12,5
	Heating	kW	4,2	5,2	5,6	7,0	8,0	11,2	14,0

Wall		S-36PK1E5A	S-45PK1E5A	S-50PK1E5A	S-60PK1E5A	S-71PK1E5A	S-100PK1E5A
Dimensions	H x W x D	mm	300 x 1.065 x 230	300 x 1.065 x 230	300 x 1.065 x 230	300 x 1.065 x 230	300 x 1.065 x 230
Sound pressure level	Cooling (Hi / Me / Lo)	dB(A)	35 / 31 / 27	38 / 34 / 30	40 / 36 / 32	47 / 44 / 40	47 / 44 / 40
	Heating (Hi / Me / Lo)	dB(A)	35 / 31 / 27	38 / 34 / 30	40 / 36 / 32	47 / 44 / 40	47 / 44 / 40
Air volume	Cooling (Hi / Me / Lo)	m³/h	660 / 570 / 450	720 / 630 / 510	840 / 720 / 630	1.080 / 870 / 690	1.080 / 870 / 690
	Heating (Hi / Me / Lo)	m³/h	660 / 570 / 450	720 / 630 / 510	840 / 720 / 630	1.080 / 870 / 690	1.080 / 870 / 690

4 Way 60x60 Cassette		S-36PY2E5A	S-45PY2E5A	S-50PY2E5A
Panel		CZ-KPY3A / CZ-KPY3B	CZ-KPY3A / CZ-KPY3B	CZ-KPY3A / CZ-KPY3B
Dimensions (H x W x D)	Indoor	mm	288 x 583 x 583	288 x 583 x 583
	Panel CZ-KPY3A	mm	31 x 700 x 700	31 x 700 x 700
	Panel CZ-KPY3B	mm	31 x 625 x 625	31 x 625 x 625
Sound pressure level	Cooling (Hi / Me / Lo)	dB(A)	36 / 32 / 26	38 / 34 / 28
	Heating (Hi / Me / Lo)	dB(A)	36 / 32 / 26	38 / 34 / 28
Air volume	Cooling / Heating	m³/h	582 / 594	600 / 618

4 Way 90x90 Cassette		S-36PU1E5A	S-45PU1E5A	S-50PU1E5A	S-60PU1E5A	S-71PU1E5A	S-100PU1E5A	S-125PU1E5A	S-140PU1E5A
Panel		CZ-KPU21	CZ-KPU21	CZ-KPU21	CZ-KPU21	CZ-KPU21	CZ-KPU21	CZ-KPU21	CZ-KPU21
Dimensions	Indoor H x W x D	mm	256 x 840 x 840	256 x 840 x 840	256 x 840 x 840	256 x 840 x 840	256 x 840 x 840	319 x 840 x 840	319 x 840 x 840
	Panel H x W x D	mm	33,5 x 950 x 950	33,5 x 950 x 950	33,5 x 950 x 950	33,5 x 950 x 950	33,5 x 950 x 950	33,5 x 950 x 950	33,5 x 950 x 950
Sound pressure level	Cooling (Hi / Me / Lo)	dB(A)	30 / 28 / 27	31 / 28 / 27	32 / 29 / 27	36 / 31 / 28	37 / 31 / 28	44 / 38 / 32	45 / 39 / 33
	Heating (Hi / Me / Lo)	dB(A)	30 / 28 / 27	31 / 28 / 27	32 / 29 / 27	36 / 31 / 28	37 / 31 / 28	44 / 38 / 32	45 / 39 / 33
Air volume	Cooling (Hi / Me / Lo)	m³/h	840 / 780 / 720	900 / 780 / 720	960 / 810 / 720	1.260 / 1.020 / 840	1.320 / 1.020 / 840	1.980 / 1.620 / 1.260	2.100 / 1.680 / 1.320
	Heating (Hi / Me / Lo)	m³/h	840 / 780 / 720	900 / 780 / 720	960 / 810 / 720	1.260 / 1.020 / 840	1.320 / 1.020 / 840	1.980 / 1.620 / 1.260	2.100 / 1.680 / 1.320

Low Static Pressure Hide Away		S-36PN1E5A	S-45PN1E5A	S-50PN1E5A	S-60PN1E5A	S-71PN1E5A	S-100PN1E5A	S-125PN1E5A	S-140PN1E5A
Dimensions	H x W x D	mm	250 x 780 x 650	250 x 780 x 650	250 x 780 x 650	250 x 1.000 x 650	250 x 1.000 x 650	250 x 1.200 x 650	250 x 1.200 x 650
Sound pressure level	Cooling (Hi / Me / Lo)	dB(A)	40 / 38 / 35	41 / 39 / 35	41 / 39 / 35	43 / 41 / 36	43 / 41 / 36	44 / 42 / 37	46 / 44 / 39
	Heating (Hi / Me / Lo)	dB(A)	40 / 38 / 35	41 / 39 / 35	41 / 39 / 35	43 / 41 / 36	43 / 41 / 36	44 / 42 / 37	46 / 44 / 39
External static pressure	High / Medium / Low	Pa	80 / 50 / 10	80 / 50 / 10	80 / 50 / 10	80 / 50 / 10	80 / 50 / 10	80 / 50 / 10	80 / 50 / 10
Air volume	Cooling / Heating	m³/h	840 / 840	960 / 960	960 / 960	1.320 / 1.320	1.320 / 1.320	2.160 / 2.160	2.280 / 2.280

Hide Away High Static Pressure		S-36PF1E5A	S-45PF1E5A	S-50PF1E5A	S-60PF1E5A	S-71PF1E5A	S-100PF1E5A	S-125PF1E5A	S-140PF1E5A
Dimensions	H x W x D	mm	290 x 800 x 700	290 x 800 x 700	290 x 800 x 700	290 x 1.000 x 700	290 x 1.000 x 700	290 x 1.400 x 700	290 x 1.400 x 700
Sound pressure level	Cooling (Hi / Me / Lo)	dB(A)	33 / 29 / 25	34 / 30 / 26	34 / 30 / 26	35 / 32 / 26	35 / 32 / 26	38 / 34 / 31	39 / 35 / 32
	Heating (Hi / Me / Lo)	dB(A)	33 / 29 / 25	34 / 30 / 26	34 / 30 / 26	35 / 32 / 26	35 / 32 / 26	38 / 34 / 31	39 / 35 / 32
External static pressure	High / Medium / Low	Pa	150 / 70 / 10	150 / 70 / 10	150 / 70 / 10	150 / 70 / 10	150 / 100 / 10	150 / 100 / 10	150 / 100 / 10
Air volume	Cooling (Hi / Me / Lo)	m³/h	840 / 780 / 600	840 / 780 / 600	960 / 900 / 720	1.260 / 1.140 / 900	1.260 / 1.140 / 900	1.920 / 1.560 / 1.260	2.040 / 1.740 / 1.380
	Heating (Hi / Me / Lo)	m³/h	840 / 780 / 600	840 / 780 / 600	960 / 900 / 720	1.260 / 1.140 / 900	1.260 / 1.140 / 900	1.920 / 1.560 / 1.260	2.040 / 1.740 / 1.380

Ceiling		S-36PT2E5A	S-45PT2E5A	S-50PT2E5A	S-60PT2E5A	S-71PT2E5A	S-100PT2E5A	S-125PT2E5A	S-140PT2E5A
Dimensions	H x W x D	mm	235 x 960 x 690	235 x 960 x 690	235 x 960 x 690	235 x 1.275 x 690	235 x 1.275 x 690	235 x 1.590 x 690	235 x 1.590 x 690
Sound pressure level	Cooling (Hi / Me / Lo)	dB(A)	35 / 32 / 30	38 / 33 / 30	38 / 33 / 30	39 / 36 / 33	39 / 36 / 33	42 / 38 / 35	45 / 40 / 37
	Heating (Hi / Me / Lo)	dB(A)	36 / 32 / 30	39 / 34 / 30	39 / 34 / 30	40 / 36 / 33	40 / 36 / 33	42 / 38 / 35	46 / 41 / 38
Air volume	Cooling (Hi / Me / Lo)	m³/h	840 / 720 / 630	900 / 750 / 630	900 / 750 / 630	1.200 / 1.020 / 870	1.260 / 1.080 / 930	1.800 / 1.500 / 1.380	2.040 / 1.680 / 1.440
	Heating (Hi / Me / Lo)	m³/h	840 / 720 / 630	900 / 750 / 630	900 / 750 / 630	1.200 / 1.020 / 870	1.260 / 1.080 / 930	1.800 / 1.500 / 1.380	2.040 / 1.680 / 1.440

Compatible Outdoor Units		7,1 kW	10,0 kW	12,5 kW	14,0 kW	7,1 kW	10,0 kW	12,5 kW	14,0 kW	20,0 kW	25,0 kW
Outdoor Single Phase		U-71PEY1E5	U-100PEY1E5	U-125PEY1E5	—	U-71PE1E5A	U-100PE1E5A	U-125PE1E5A	U-140PE1E5A	—	—
Outdoor Three Phase		—	U-100PEY1E8	U-125PEY1E8	U-140PEY1E8	U-71PE1E8A	U-100PE1E8A	U-125PE1E8A	U-140PE1E8A	U-200PE1E8	U-250PE1E8
Cooling capacity	Nominal (Min - Max)	kW	7,1 (2,0 - 7,7)	10,0 (2,7 - 11,5)	12,5 (3,8 - 13,5)	14,0 (3,3 - 15,5)	7,1 (2,5 - 8,0)	10,0 (3,3 - 12,5)	12,5 (3,3 - 14,0)	14,0 (3,3 - 15,5)	20,0 (6,0 - 22,4)
Heating capacity	Nominal (Min - Max)	kW	7,1 (1,8 - 8,1)	10,0 (2,1 - 13,8)	12,5 (3,4 - 15,0)	14,0 (4,1 - 16,0)	8,0 (2,0 - 9,0)	11,2 (4,1 - 14,0)	14,0 (4,1 - 16,0)	16,0 (4,1 - 18,0)	21,8 (6,0 - 22,4)
Power source	Single Phase	V	220 / 230 / 240	220 / 230 / 240	220 / 230 / 240	—	220 / 240	220 / 240	—	—	—
	Three Phase	V	—	380 / 400 / 415	380 / 400 / 415	380 / 415	380 / 415	380 / 415	380 / 415	380 / 415	380 / 415
Connection		mm²	2,50	4,00	6,00	2,50	2 x 1,5 or 2,5	2 x 1,5 or 2,5	2 x 1,5 or 2,5	—	—
Air volume	Cooling / Heating	m³/h	2.340	4.560 / 4.020	4.800 / 4.380	8.100 / 7.200	3.600 / 3.600	6.600 / 5.700	7.800 / 6.600	8.100 / 7.200	7.740
Sound pressure level	Cooling / Heating (Hi)	dB(A)	50 / 52	54 / 54	56 / 56	54 / 53	48 / 50	52 / 52	53 / 53	54 / 55	57 / 57
	Cooling / Heating (Hi)	dB	70 / 70	70 / 70	73 / 73	71 / 70	65 / 67	69 / 69	70 / 70	71 / 71	72
Dimensions	H x W x D	mm	569x790x285	996x940x340	996x940x340	1.416x940x340	996x940x340	1.416x940x340	1.416x940x340	1526x940x340	1526x940x340
Net weight		kg	42	73	85	98	69	98	98	118	128
Piping connections	Liquid pipe	Inch (mm)	3/8 (9,52)	3/8 (9,52)	3/8 (9,52)	3/8 (9,52)	3/8 (9,52)	3/8 (9,52)	3/8 (9,52)	3/8 (9,52)	1/2 (12,7)
	Gas pipe	Inch (mm)	5/8 (15,88)	5/8 (15,88)	5/8 (15,88)	5/8 (15,88)	5/8 (15,88)	5/8 (15,88)	5/8 (15,88)	1 (25,4)	1 (25,4)
Refrigerant Loading	R410A	kg	1,7	2,60	3,20	3,4	2,35	3,4	3,4	5,3	6,5
Elevation difference (in/out)	Max	m	30	30	30	30	30	30	30	30	30
Piping length	Min / Max	m	5 / 50	5 / 50	5 / 50	5 / 50	5 / 75	5 / 75	5 / 75	5 / 100	5 / 100
Operating range	Cooling Min / Max	°C	-10 / +43	-10 / +43	-10 / +43	-10 / +43	-15 / +46	-15 / +46	-15 / +46	-15 / +46	-15 / +43
	Heating Min / Max	°C	-15 / +24	-15 / +24	-15 / +24	-15 / +24	-20 / +24	-20 / +24	-20 / +24	-20 / +24	-20 / +15



Panasonic Ventilation Solutions

For maximum savings and easy integration.



Panasonic AHU Kit, 10-25 kW connected to PACi outdoor unit

Heat exchanger, Fan & Fan motor to be mounted in AHU Kit shall be provided in the field. AHU connection Kit (field supplied) AHU Kit system. (Contents of kit: Control for PCB, expansion valve, sensors).

Application: Hotels, offices, server rooms or all large buildings where air quality control such as humidity control and fresh air and is needed.

AHU Kit combine air conditioning and fresh air in just one solution.



Air Curtain with DX Coil

Highly efficient heating effect

The combined air stream, which has a desirable low air current induction factor (mixing factor), can carry the selected initial temperature effect over long distances, and will reach the floor area while still at room temperature. This is necessary to avoid cooling down the interior spaces.

AHU Kit connects PACi outdoor units to Air Handling Units system

The Panasonic AHU Kits offer a wealth of connectivity possibilities so can be easily integrated into many systems.

Application: Hotels, offices, server rooms or all large buildings where air quality control such as humidity control and fresh air and is needed. Besides the advantages in terms of indoor air quality, air conditioning offers also an energy saving potential. For example, while uncontrolled ventilation through open windows leads to large amounts of heat being lost to the

outside during the heating season or gained from the outside during the cooling season, air conditioning systems provide possibilities to utilize the extra "free" energy in heat recovery modules so that overall operating costs will be reduced.

The larger the area of the comfort range, the better the energy saving opportunities.

Air Curtain with DX Coil

The Panasonic range of air curtains is designed for smooth operation and efficient performance. Air curtains produce a continuous stream of air blown from the top to the bottom of an open doorway and create a barrier that people and products can flow across, but air can't. Designed to improve energy efficiency, minimise heat loss from a building, and to allow retailers to keep doors open to encourage customers, our Air Curtains are suitable for connection to both VRF and PACi Systems.

Heating capacity comparison: Electrical air curtain / Panasonic air curtain

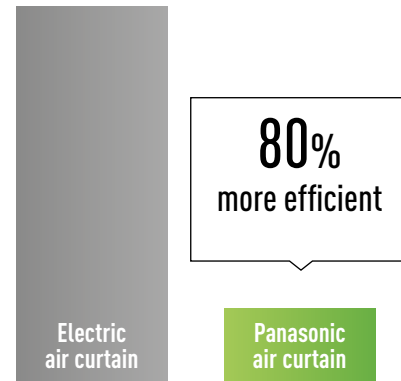

* With the U-100PE1E5 on the PAW-20PAIRC-MS. Calculation method: Taking as consideration SCOP of the Panasonic combination of 6.0. If 100 is the energy needed for a air curtain, Panasonic Air curtain will need 1/(1-6)*100=20.

Electric Air Curtain

Air curtains can help reduce whole building heating or cooling costs by helping to stop heat escaping the building or keeping cooled air in. Panasonic offers two sizes - 900mm and 1200mm electric air curtains. Ideal for separating areas and energy saving.



Technical focus

- 2 sizes: 900 mm and 1.200 mm
- Powerful air flow (10 m/s)
- Very low noise, only 42 dB

Comfort

- Easy redirection of airflow by means of the manual deflector

Ease of use

- Speed selector (high and low) on the unit itself

Easy installation and maintenance

- Simple installation
- Compact dimensions improve installation and positioning in any space

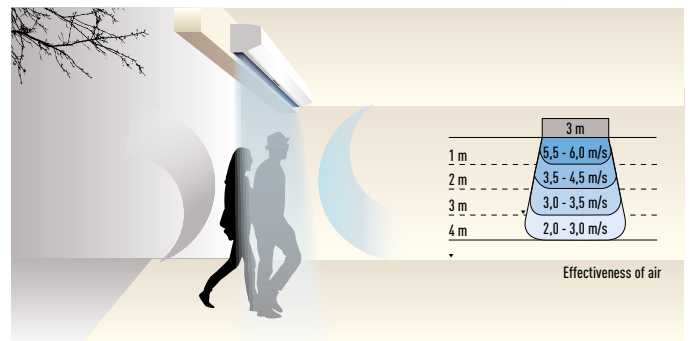

			FY-10ESPNAH	FY-10ELPNAH
Width			900	1.200
Watts	Hi	W	71,5	96
	Lo	W	61,5	74
Current	Hi	A	0,40	0,54
	Lo	A	0,29	0,35
Air speed	Hi	m/s	13,0	13,1
	Lo	m/s	11,1	11,0
Air volume	Hi	m³/h	750	1.000
	Lo	m³/h	630	830
Noise lever	Hi	dB(A)	46	46
	Lo	dB(A)	42	41
Weight		kg	11	14

Air Handling Unit Kit 10-25 kW for PACi

Panasonic AHU Kit, 10-25 kW connected to PACi outdoor unit

The new Air Handling Unit Kit has been developed to better meet customer demand:

- IP 65 Box in order to be installed outside
- 0-10V demand control*
- Easy control by BMS

* Only available with Elite PACi, up to from 6kW to 14kW.

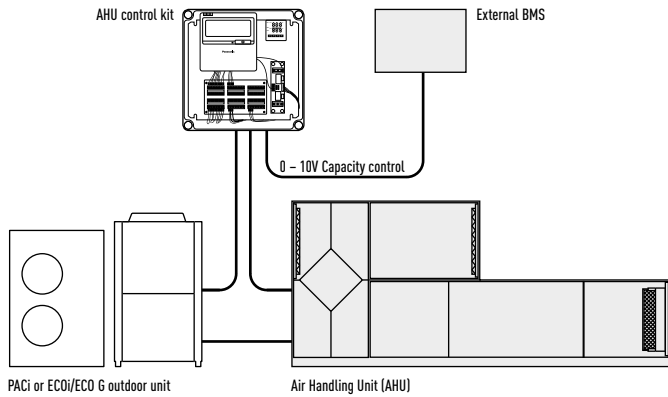

Demand control on the outdoor unit managed by external 0-10 V signal.

Control opción 1: CZ-280PAH1 / PAW-280PAH2L

- El sistema se controla de forma sencilla; control de temperatura de aspiración Vs "setpoint"
- Control como el de cualquier unidad interior
- Señal de ventilador desde PCB (Off cuando defrost, por ejemplo)

Control opción 2: PAW-280PAH2

- Control del sistema por sonda en impulsión de aire. El sensor actúa sobre un termostato de control 0-10V que gestiona la 1ª setpoint. Control de prevención de "Cold Draft"
- Todas las señales igual que el standard

Control opción 3: PAW-280PAH2

- Control del sistema por sonda ambiente exterior. El sensor actúa sobre un termostato de control 0-10V que gestiona la 1ª setpoint. Mejora la eficiencia, ajustando la capacidad a la 1ª ambiente y mejora el confort
- Todas las señales igual que el standard

Control opción 4: PAW-280PAH2

- Control del sistema por control 0-10V desde un BMS externo que gestiona la 1ª setpoint o capacidad. Mejora la eficiencia, ajustando la capacidad a la 1ª ambiente y mejora el confort
- Todas las señales igual que el standard

Optional parts: Following functions are available by using different control accessories:

CZ-RTC4 Timer remote controller

- Operation-ON/OFF
- Mode select
- Temperature setting

* Fan operation signal can be taken from the PCB.

CZ-CAPBC2 Mini seri-para I/O unit (advanced version only)

- Easy integration in external AHU control systems and BMS
- Demand control: 40 to 115 % (5 % steps) of nominal current by 0-10 V input signal*
- Target temperature setting by 0-10 V or 0-140 Ω input signal*
- Room supply air temperature output by 4-20 mA signal
- Mode select or/and ON/OFF control
- Fan operation control
- Operation status output/ Alarm output
- Thermostat ON/OFF control

* Demand control by external BMS cannot be combined with the demand control or target temperature setting accomplished by the thermostat. However, if simultaneous demand control and target temperature setting is needed, this can only be achieved by using a second (optional) CZ-CAPBC2 interface.

Main components of mechanical ventilation systems

The main components of a mechanical ventilation system are the following: Air Handling Unit (AHU), air ducts and air distribution elements.

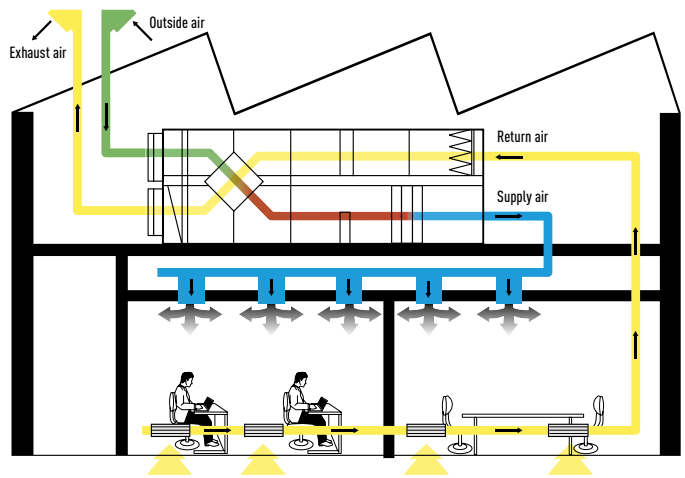

0-10V control

With the 0-10 v demand control the capacity of the outdoor unit can be controlled by 20 steps.

With the included resistance. 0-10V control scheme with 10V= maximum capacity

Input Voltage* (V)	0 - 0,55	1,1	1,65	2,2	2,8	3,35	3,9	4,45	5,0	5,55	6,1	6,65	7,2	7,8	8,35	8,9	9,45	10,0
Demand (% of nominal current)	Stop ¹	40	45	50	55	60	65	70	75	80	85	90	95	100	105	110	115	No limit / Full capacity ²

When you remove the resistance. 0-10V control scheme with 10V= Thermo-Off

Input Voltage* (V)	0 - 0,5	1,0	1,5	2,0	2,5	3,0	3,5	4,0	4,5	5,0	5,5	6,0	6,5	7,0	7,5	8,0	8,5	9,0	9,5 - 10,0
Demand (% of nominal current)	Stop ¹	40	45	50	55	60	65	70	75	80	85	90	95	100	105	110	115	No limit ²	Thermo-Off ³

* If a voltage range [0 - 0,5 or 9,5 - 10,0V] is indicated, the applied voltage must be within the given limits.

However, if a single value (e.g. 1,0V) is indicated, the applied voltage must be within +/-0,1V of the given value to achieve the assigned demand setting.

Examples: "Stop" can be achieved with any analogue input value greater than 0V and less than or equal to 0,5 V; 40% demand can be achieved with any analogue input value greater than or equal to 0,9V and less than or equal to 1,1V etc.

1) Stop: AHU system / indoor unit is completely switched off.

2) No Limit: No restrictions applied by BMS to AHU system / indoor unit performance [equivalent to "full-load operation" of AHU system / indoor unit.

3) Thermo-Off: No cooling / heating operation [compressor is switched off; however, the fans may still be operating]. For example, forced Thermostat-Off mode can be used for free cooling.

PAW-OCT, DC12 V outlet. OPTION terminal

- Output signal= Cooling/Heating/Fan status
- Defrost
- Thermostat-ON

CZ-T10 terminal / PAW-T10 PCB to connect to T10 connector

- A Dry contact PCB has been developed to easily control the unit
- Input signal operation ON/OFF
- Remote control prohibition
- Output signal Operation ON status maximum 230 V 5 A (NO/NC)
- Output signal alarm status max. 230 V 5 A (NO/NC)
- Alarm output (by DC12V)
- Additional available contacts:
 - External humidifier control (ON/OFF) 230 VAC 3 A
 - External fan control (ON/OFF) 12V DC
 - External filter status signal potential free
 - External float switch signal potential free
 - External leakage detection sensor or TH. OFF contact potential free (possible usage for external blow out temperature control)



New AHU Kit connects PACi outdoor units to Air Handling Units system

The Panasonic AHU Kits offer a wealth of connectivity possibilities so can be easily integrated into many systems.

Application: Hotels, offices, server rooms or all large buildings where air quality control such as humidity control and fresh air and is needed.

2 types of AHU Kit: Advanced and Standard

Model Code	IP 65	0-10V demand control*	Outdoor temperature shift compensation. Cold draft prevention
CZ-280PAH1			
PAW-280PAH2	Yes	Yes	Yes
PAW-280PAH2L	Yes	No	No

* With CZ-CAPBC2.

System & regulations. System overview

- AHU Kit equipment (Field supplied)
- AHU Kit system controller (Field supplied)
- AHU Kit controller box (with control PCB)
- Thermistor for Gas pipe (E2)
- Thermistor for Liquid pipe (E1)
- Thermistor for Suction air
- Inter-unit wiring
- Outdoor unit

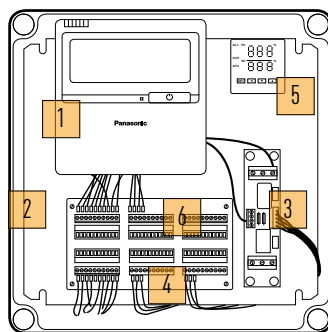
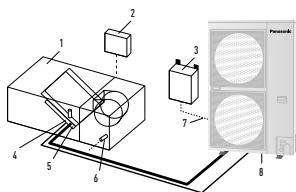

- Remote control CZ-RTC4
- New plastic IP 65 Box
- PAW-T10 PCB for dry contact
- 0-10V demand control PCB
- Intelligent thermostat for:
 - Cold draft prevention
 - Outdoor temperature shift compensation
- Terminal base for sensors and power supply

AHU Connection Kit

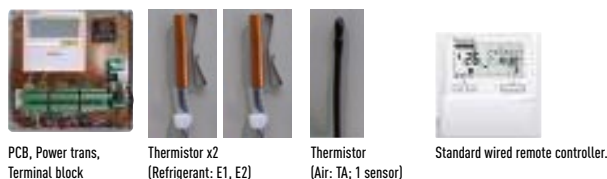

Included Timer remote controller CZ-RTC4

AHU PACi Elite	Cooling capacity		Heating capacity		Air volume		Dimensions		Piping length		Elevation difference (in/out)	
	Nominal kW		Nominal kW		High / Low m³/min		H x B x D mm		Min / Max m		Min / Max m	
PAW-280PAH2	6 / 25		7 / 28		480 / 4.440		404 x 425 x 78		5 / 30*		10	
PAW-280PAH2+PAW-280PAH2	50,0		56,0		2.280 / 8.880		404 x 425 x 78		5 / 30*		10	

* For U-200PE1E8A and U-250PE1E8.

AHU connection kit / System combination	Capacity kW	Outdoor unit	AHU	Air volume		Dimensions		Piping length		Elevation difference (in/out)		Piping connections	
				High / Low m³/min		H x B x D mm		Min / Max m		Min / Max m	Liquid pipe Tum (mm)	Gas pipe Tum (mm)	
	5,0	U-50PE1E5	PAW-280PAH2	480 / 780		404 x 425 x 78		5 / 30		10	1/4 (6,35)	1/2 (12,7)	
	6,0	U-60PE1E5A	PAW-280PAH2	540 / 960		404 x 425 x 78		5 / 30		10	3/8 (9,62)	5/8 (15,88)	
	7,5	U-71PE1E5A/U-71PE1E8A	PAW-280PAH2	720 / 1.500		404 x 425 x 78		5 / 30		10	3/8 (9,62)	5/8 (15,88)	
	10,0	U-100PE1E5A/U-100PE1E8A	PAW-280PAH2	840 / 1.980		404 x 425 x 78		5 / 30		10	3/8 (9,62)	5/8 (15,88)	
	12,5	U-125PE1E8A	PAW-280PAH2	1.140 / 2.100		404 x 425 x 78		5 / 30		10	3/8 (9,62)	5/8 (15,88)	
	14,0	U-140PE1E8A	PAW-280PAH2	1.140 / 2.100		404 x 425 x 78		5 / 30		10	3/8 (9,62)	5/8 (15,88)	
	20,0	U-200PE1E8A	PAW-280PAH2	1.680 / 3.960		404 x 425 x 78		5 / 70		10	3/8 (9,62)	1 (25,4)	
	25,0	U-250PE1E8A	PAW-280PAH2	2.280 / 4.440		404 x 425 x 78		5 / 70		10	1/2 (12,7)	1 (25,4)	
	50,0	U-250PE1E8A + U-250PE1E8A	PAW-280PAH2 + PAW-280PAH2	2.280 / 8.880		404 x 425 x 78		5 / 70		10	2 x 1/2 (12,7)	2 x 1 (25,4)	

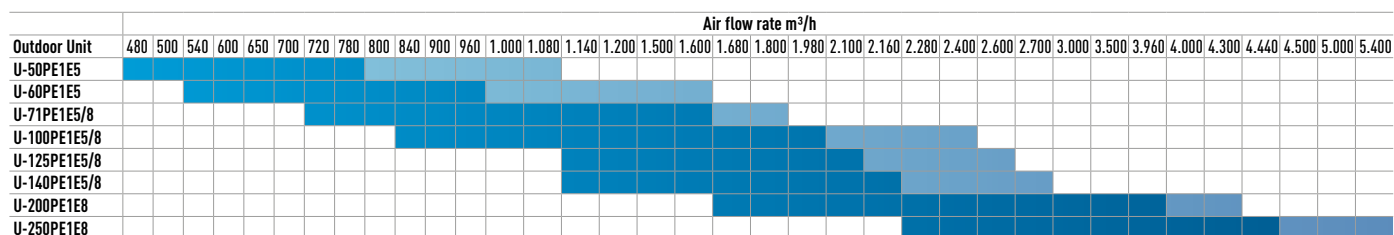

Standard condition in cooling mode intake air temperature. Rating Conditions: Cooling Indoor 27°C DB / 19°C WB.

Maximum condition in cooling mode intake air restriction temperature Min18°C DB / 13°C WB Max 32°C DB / 23°C WB

Air Curtain with DX Coil, connected to the VRF or PACi Systems

Highly efficient heating effect

The combined air stream, which has a desirable low air current induction factor (mixing factor), can carry the selected initial temperature effect over long distances, and will reach the floor area while still at room temperature. This is necessary to avoid cooling down the interior spaces. Available in different lengths to suit requirements between 1 and 2,5 m, both air curtains have outlet grilles that can be adjusted to five different positions. The jet flow model can be installed up to a height of 3,5 m with the standard model up to 3,0 m. The outlet grilles can be easily adjusted into five positions to suit different installations requirements and the air filter can be accessed without the need for specialist tools.

- Super-efficient with new EC fan motor (40% lower running costs compared to a standard AC fan motor)
 - Easy Cleaning and Servicing
 - Can be connected to either Panasonic VRF or PACi systems
 - Built-in drain for cooling operation
 - Standard and Jet Flow air curtains can be controlled via Panasonic's range of remote internet controls
- The new standard and jet-flow models are ideal for connection to a ECOi or PACi system. With simple "plug and play" installation, both are fitted with an EC fan motor for a smooth operation and efficient performance. This new fan guarantees 40% lower running cost than with a standard AC fan motor. With air curtains often running for 12 hours a day as a minimum, this can lead to considerable savings.

Optimised airflow velocity

1. Energy losses, no air curtain installed
2. Too low velocity air curtain – air curtain not efficient
3. Optimum results with the Tekadoor air curtain connected to Panasonic VRF
4. Too high velocity air curtain – considerable turbulence, energy lost to the outside, air curtain not efficient

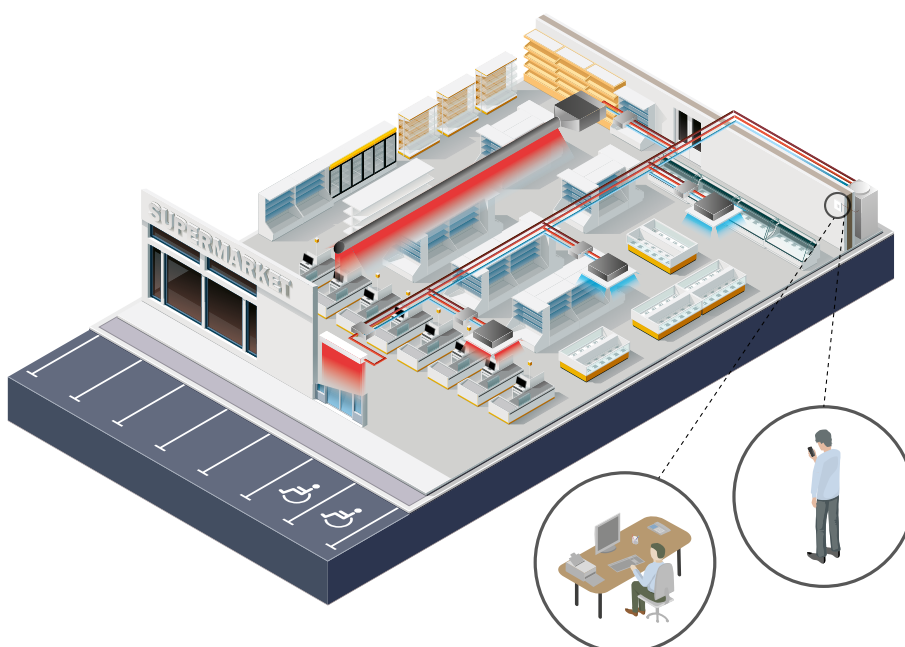
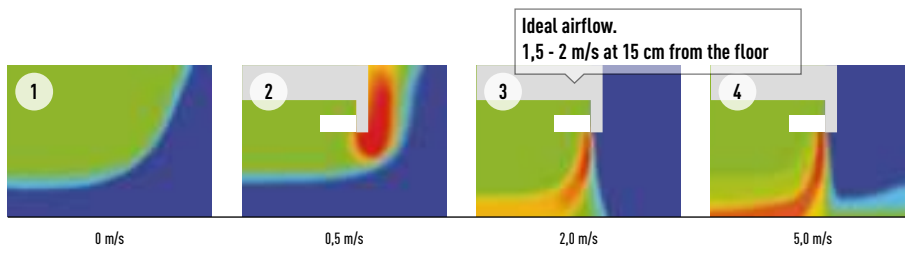

Intelligent Operation

Our air curtains combine airflow and heating / cooling technology to ensure optimum comfort and energy efficiency whilst also creating an effective barrier between indoor and outdoor environments. Design and installation is key to achieving the correct height / temperature settings to achieve optimum performance. Our air curtains are designed to answer the demands of the retail, commercial and industrial markets.

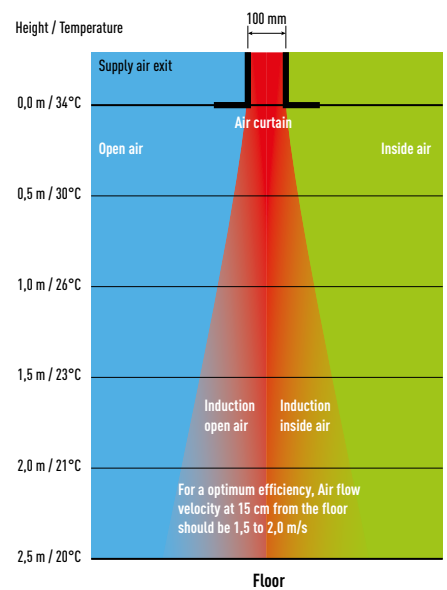

How does it work?

Stale air from the room is taken in and ejected near the door. This creates a 'roll of air' that shields the door area, mixing with the colder incoming air. It then turns away from the door, back into the room and toward the intake screen, where it is partly drawn in again. This flow of air helps to create a barrier for heat loss yet at the same time refreshes room air.

Internet Control

An app added to your tablet or smartphone or via the Internet allows you to control and manage the system remotely. There is also the option to integrate into existing BMS systems by using other Panasonic interfaces.



High efficiency Air curtain connected to your VRF installation. EC Fan motor for a smooth operation and efficient performance. 2 types of Air flow available: Jet-Flow and Standard. 2015 Fan Standard available today. Easy Cleaning and Servicing.

Technical focus

- Save up to 40% Energy Costs by use of the integrated EC Fan Technology (Higher efficiency than conventional AC fan, soft start and longer motor duration)
- 3 Lengths of Air Curtains Jet-Flow, from 1,0 to 2,0 m and 2 lengths of Air Curtains Standard, 1,0 and 2,0 m
- Installation Height up to 3,5 m (Jet-Flow) and 3,0 m (Standard)
- Outlet Grilles can be adjusted in five positions, to suite different Indoor and installation requirements (Jet-Flow)
- Control with Panasonic Remote Control systems (optional)
- Direct integration to BMS by optional Panasonic Interfaces
- Drain included for cooling operation

Comfort

- Easy redirection of Airflow by means of manual deflector (Jet-Flow)

Ease of use

- Speed selectable on remote controller with 3 speeds

Easy installation and maintenance

- Easy installation
- Compact dimensions improve installation and positioning (Jet-Flow)
- Easy cleaning of grid without opening of the unit
- Continuous operation even in case of 1 fan motor failure without stopping air curtain function or stopping the complete system
- Warning indication on remote controller display

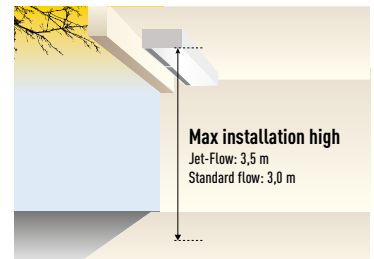

HP			4 HP	6 HP	8 HP	4 HP	8 HP		
Air Curtain			PAW-10PAIRC-MJ	PAW-15PAIRC-MJ	PAW-20PAIRC-MJ	PAW-10PAIRC-MS	PAW-20PAIRC-MS		
Air flow type			Jet-Flow			Standard			
Air Flow Length (A)			m	1,0	1,5	2,0	1,0	2,0	
Air volume	High	m³/h	1.800	2.700	3.600	1.800	2.700		
	Medium	m³/h	1.500	2.300	3.000	1.500	2.300		
	Low	m³/h	1.200	1.900	2.500	1.200	1.900		
Cooling capacity nominal ¹			kW	9,2	17,5	23,1	9,2	17,5	
Heating capacity with air in 20°C, air out 40°C			kW	11,9	17,9	23,9	11,9	17,9	
Heating capacity with air in 20°C, air out 35°C			kW	8,9	13,4	17,9	8,9	13,4	
Heating capacity with air in 20°C, air out 30°C			kW	5,9	8,9	11,9	5,9	8,9	
Max installation height	Good condition	m	3,5	3,5	3,5	3,0	3,0		
	Normal condition	m	3,1	3,1	3,1	2,7	2,7		
	Bad condition	m	2,7	2,7	2,7	2,4	2,4		
Refrigerant			R410A	R410A	R410A	R410A	R410A		
Liquid pipe			Inch (mm)	3/8 (9,52)	3/8 (9,52)	3/8 (9,52)	3/8 (9,52)	3/8 (9,52)	
Gas pipe			Inch (mm)	5/8 (15,88)	3/4 (19,05)	7/8 (22,22)	5/8 (15,88)	7/8 (22,22)	
Fan			230V / 50Hz / 1 / N / PE			230V / 50Hz / 1 / N / PE			
Fan type			EC			EC			
Currency	High / Med / Low	A	2,1 / 0,8 / 0,3	2,8 / 1,1 / 0,4	4,2 / 1,6 / 0,6	2,1 / 0,8 / 0,3	4,2 / 1,6 / 0,6		
Electrical Consumption	High / Med / Low	kW	0,44 / 0,17 / 0,06	0,59 / 0,23 / 0,08	0,89 / 0,34 / 0,12	0,44 / 0,17 / 0,06	0,89 / 0,34 / 0,12		
Protecting Fuse			A	M16A	M16A	M16A	M16A		
Noise			dB(A)	40-55	40-56	40-57	40-55	40-57	
Dimensions			W x H x D	mm	1.210 x 260 x 590	1.710 x 260 x 590	2.210 x 260 x 590	1.210 x 260 x 490	2.210 x 260 x 490
Weight			kg	70	100	138	60	128	
Outdoor combination with PACi Elite unit 40°C			U-100PE1E5/8	U-140PE1E5/8	U-200PE1E8	U-100PE1E5/8	U-140PE1E5/8		
Outdoor combination with PACi Standard unit 40°C			U-100PE1E5/8	—	—	U-100PE1E5/8	—		
Outdoor combination with PACi Elite unit 35°C			U-71PE1E5/8	U-100PE1E5/8	U-140PE1E5/8	U-71PE1E5/8	U-100PE1E5/8		
Outdoor combination with PACi Standard unit 35°C			U-100PE1E5/8	U-100PE1E5/8	—	U-100PE1E5/8	U-100PE1E5/8		
Outdoor combination with PACi Elite unit 30°C			U-50PE1E5	U-100PE1E5/8	U-100PE1E5/8	U-50PE1E5	U-100PE1E5/8		
Outdoor combination with PACi Standard unit 30°C			U-60PEY1E5	U-100PEY1E5/8	U-100PEY1E5/8	U-60PEY1E5	U-100PEY1E5/8		

All combinations under rated conditions: Heating Outdoor +7°C DB/+6°C WB Indoor +20°C DB. In case of lower outdoor temperatures a higher capacity outdoor unit model may be necessary.
 1) Rated Conditions Cooling Outdoor +35°C DB Indoor +27°C DB/+19°C WB, Discharge temperature ³ 16°C.

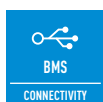



R22 Renewal

Why renewal?

Unique R22 Renewal from Panasonic: Fast, easy to install and Cost effective

- Panasonic refrigerant oil doesn't react to the most common oil types used in air-conditioning systems. This ensures the mix of oil does not damage the units. Therefore installations are easier.
- All Panasonic PACi units can be installed in R22 pipings, no specific models are available.
- Up to 33 Bar! When there is any doubt about the strength of the piping, the maximum working pressure can be reduced to 33 Bar with a setting in the software of the outdoor unit.

An important drive to further reduce the potential damage to our ozone

It is often said that legislation is ruling our lives but sometimes it is there to help save lives. R22 phase out can be described as one of these and from Jan 1st 2010 the use of Virgin (new) R22 refrigerant was banned within the European Community.

Panasonic are doing our part

We at Panasonic are also doing our part – recognising that all finances are under pressure at the moment. Panasonic has developed a clean and cost effective solution to enable this latest legislation to be introduced with as minimum an effect on businesses and cash reserves as possible.

The Panasonic renewal system allows good quality existing R22 pipe work to be re-used whilst installing new high efficiency R410A systems.

By bringing a simple solution to the problem Panasonic can renew all Split Systems and PACi systems; and depending upon certain restrictions we don't even limit the manufacturer's equipment we are replacing.

By installing a new high efficiency Panasonic R410A system you can benefit from around 30% running cost saving compared to the R22 system.

Yes...

1. Check the capacity of the system you wish to replace
2. Select from the Panasonic range the best system to replace it with
3. Follow the procedure detailed in the brochure and technical data Simple...

R22 - The reduction of Chlorine critical for a cleaner future

Reuse of existing piping (Renewal Design & Installation)

Notes on reuse of existing refrigerant piping

It is possible for each series of PE1 type and PEY1 type outdoor unit to reuse the existing refrigerant piping without cleaning when obtained under certain conditions.. Make sure that the requirements under the section "Notes on reuse of existing refrigerant piping", "Measurement procedure for renewal" and "Refrigerant piping size and allowable piping length" will be satisfied in order to carry out .

Also, check the items with regard to section "Safety" and "Cleaning".

1. Prerequisite

- If the refrigerant used for the existing unit is other than R22, R407C and R410A, the existing refrigerant piping cannot be used.
- If the existing unit has another use than air conditioning, then existing refrigerant piping cannot be used.

2. Safety

- If there is a hollow, crack or corrosion on the piping, make sure to install new piping.
- If the existing piping is other than capable of reuse of piping as shown in the flowchart, make sure to install new piping.
- In case of multiple operation type, use our genuine branch piping for refrigerant R410A.

A local supplier shall assume responsibility for the defects and hollows on the reuse of existing piping surface and recognition of reliability of the piping strength. There is no guarantee that we take responsibility for such damages. The operational pressure of the refrigerant R410A becomes higher compared to R22. In the worst case, a lack of compressive strength may lead to piping explosion.

3. Cleaning

- When the refrigerant oil used for the existing unit is other than the listed below, make sure to install new piping or wash it thoroughly before reusing it.

[Mineral Oil] SUNISO, FIORE S, MS

[Synthesized oil] alkyl benzene oil (HAB, parallel freeze), ester oil, ether oil (PVE only)

If the existing unit is GHP type, it is necessary to wash the piping thoroughly.

- If the existing pipes in the outdoor and indoor units remain disconnected, make sure to install a new piping or wash it thoroughly before reusing it.
- If the discoloured oil or residue remains in the existing piping, make sure to install a new piping or wash it thoroughly before reusing it. See "Deterioration Criteria for Refrigerant Oil" in table 3.
- If the compressor of the existing air conditioner has a failure history, make sure to install a new piping or wash it through thoroughly before reusing it.

When reusing the existing piping as it is without removing dirt and dust, inadequate piping could result a renewal appliance in failure.

Notes on renewal for simultaneous operation of multiple units

Only main pipe is applicable for using the different diameter size.

In case of different diameter size for the branch pipes, a new installation work for a standard size is necessary.

Be sure to use our genuine branch piping for refrigerant R410A.

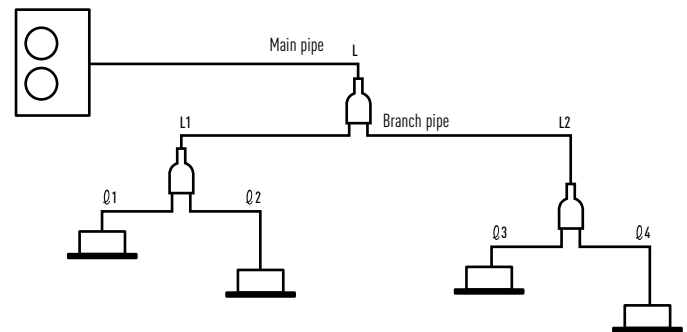

Notes on Renewal for Simultaneous Operation of Multiple Units

Capacity class	Standard liquid pipe size	Standard gas pipe size
Type 50	Ø 6,35	Ø 12,7
Type from 60 to 140	Ø 9,52	Ø 15,88
Type 200	Ø 9,52	Ø 25,4
Type 250	Ø 12,7	

- Only the main pipe L can be used among different diameter's existing piping.
- Installation work as a standard size is capable for L1, L2, L1 - L4 piping.
- Be sure to use our genuine branch piping for refrigerant R410A.

1. In case of single unit

It is not necessary to charge with additional refrigerant until the chargeless pipe length in the table 2.

If the pipe length is exceeding the charge less pipe length, charge with additional refrigerant amount per 1 m according to the equivalent length.

2. In case of simultaneous operation of multiple units

Calculate the refrigerant charging amount according to the calculating method of the standard piping diameter.

As to the additional refrigerant charging amount per 1 m, refer to the additional amount in the table 2.

R22 Renewal

Measurement Procedure for Renewal

Observe the following procedure when reusing the existing piping or carrying out renewal installation work.
Flowchart of Existing Piping Measures Criteria for PE1 Type and PEY1 Type Outdoor Unit

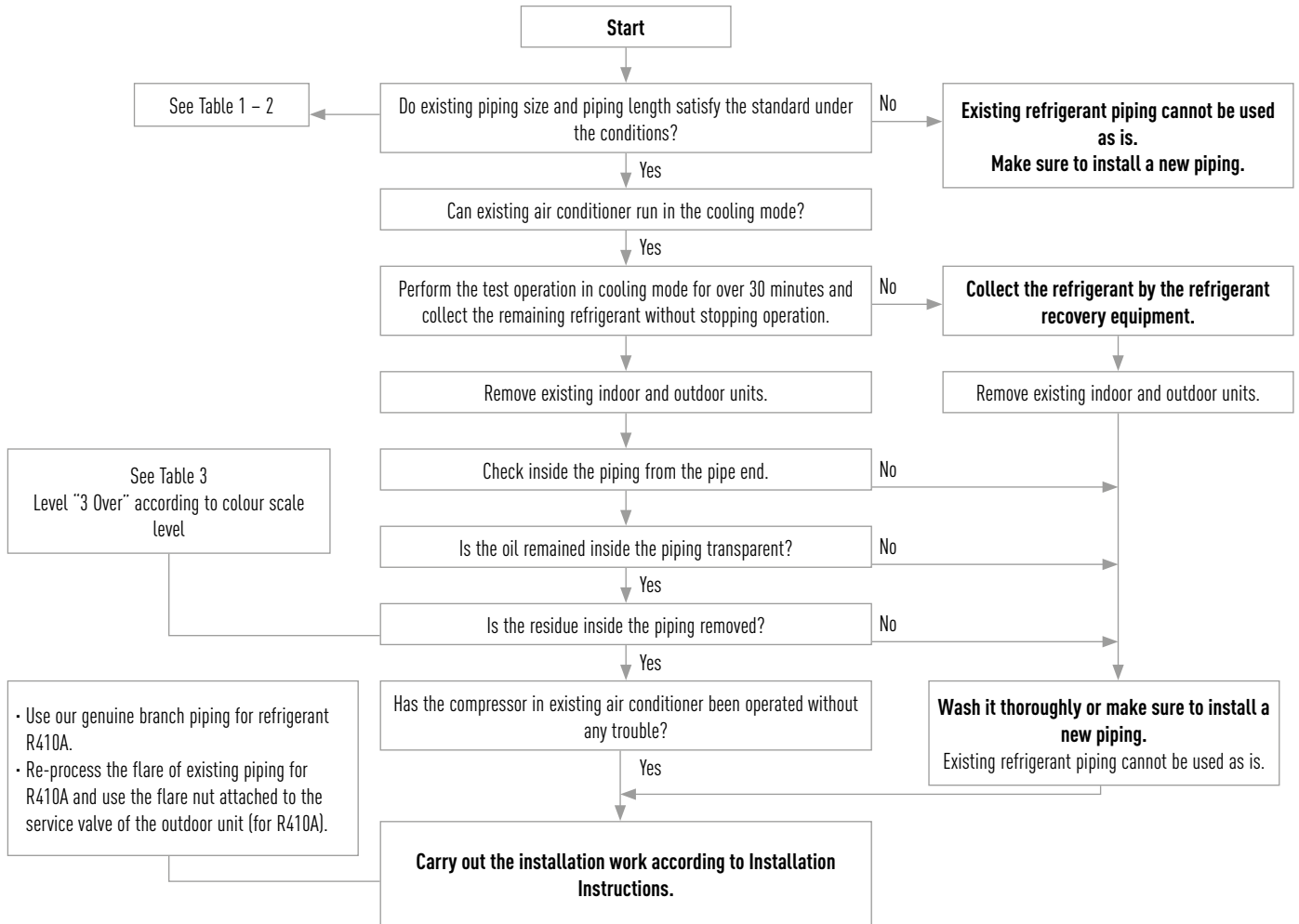

Opposite side dimension of flare nut (mm)					
Piping size	Ø 6,35	Ø 9,52	Ø 12,7	Ø 15,88	Ø 19,05
For R410A			26	29	
For R22/R407C	17	22	24	27	36

Refrigerant piping size and allowable piping length

Check if reuse of existing refrigerant piping is possible based on the following chart.

The standards other than this one (difference of elevation, etc.) are identical to the requirements of ordinary refrigerant piping.

Table 1 Reusable existing piping (mm)

Material	0				1/2 H, H*			
External diameter	Ø 6,35	Ø 9,52	Ø 12,7	Ø 15,88	Ø 19,05	Ø 22,22	Ø 25,4	Ø 28,58
Thickness	0,80	0,80	0,80	1,00	1,00	1,00	1,00	1,00

* It is impossible to reuse the size of Ø 19,05, Ø 22,22, Ø 25,4 and Ø 28,58 for material 0. Change to material 1/2H or material H.

Table 2 - 1 Refrigerant piping size: 3,6 - 14,0 kW type (mm)

Liquid pipe		Ø 6,35			Ø 9,52			Ø 12,7		
Gas pipe		Ø 9,52	Ø 12,7	Ø 15,88	Ø 12,7	Ø 15,88	Ø 19,05	Ø 15,88	Ø 19,05	
PE	Type 50	✗	Standard 40 m (30 m)	⊙ 40 m (30 m)	□ 20 m (15 m)	□ 20 m (15 m)	✗	✗	✗	
	Type 60 Type 71	✗	▽ 10 m (10 m)	□ 10 m (10 m)	▽ 30 m (20 m)	Standard 50 m (20 m)	✗	□ 25 m (10 m)	✗	
Additional refrigerant charging amount per 1 m		20 g/m			40 g/m			80 g/m		
PE	Type 60 Type 71	✗	▽ 10 m (10 m)	□ 10 m (10 m)	▽ 30 m (30 m)	Standard 50 m (30 m)	✗	□ 25 m (15 m)	✗	
	Type 100 Type 125 Type 140	✗	✗	✗	✗	Standard 75 m (30 m)	⊙ 75 m (30 m)	□ 35 m (15 m)	□ 35 m (15 m)	
PEY	Type 100 Type 125 Type 140	✗	✗	✗	✗	Standard 50 m (30 m)	⊙ 50 m (30 m)	□ 25 m (15 m)	□ 25 m (15 m)	
	Additional refrigerant charging amount per 1 m	20 g/m			50 g/m			80 g/m		

How to see table definition (example):

In case of type 71, standard size is liquid pipe Ø 9,52 / gas pipe Ø 15,88,

There is a limitation to liquid pipe Ø 9,52 / gas pipe Ø 12,7 and to liquid pipe Ø 12,7 / gas pipe Ø 15,88,

However, they are applicable for different diameter's pipes.

Table 2 - 2 Refrigerant piping size: 20,0 - 25,0 kW type (mm)

Liquid pipe		Ø 9,52			Ø 12,7			Ø 15,88		
Gas pipe		Ø 22,22	Ø 25,4	Ø 28,58	Ø 22,22	Ø 25,4	Ø 28,58	Ø 22,22	Ø 25,4	Ø 28,58
PE	Type 200	▽ 80 m (30 m)	Standard 100 m (30 m)	⊙ 100 m (30 m)	▽ 50 m (15 m)	□ 50 m (15 m)	□ 50 m (15 m)	✗	✗	✗
	Type 250	✗	✗	✗	▽ 80 m (30 m)	Standard 100 m (30 m)	⊙ 100 m (30 m)	▽ 65 m (20 m)	□ 65 m (20 m)	□ 65 m (20 m)
Additional refrigerant charging amount per 1 m		40 g/m			80 g/m			120 g/m		

- ⊙ Allowable
- ▽ Cooling capacity down
- Limited piping length
- ✗ Unallowable
- 50 m Maximum piping length
- (50 m) Charge less piping length in a single connection

Table 3 Deterioration Criteria for Refrigerant Oil

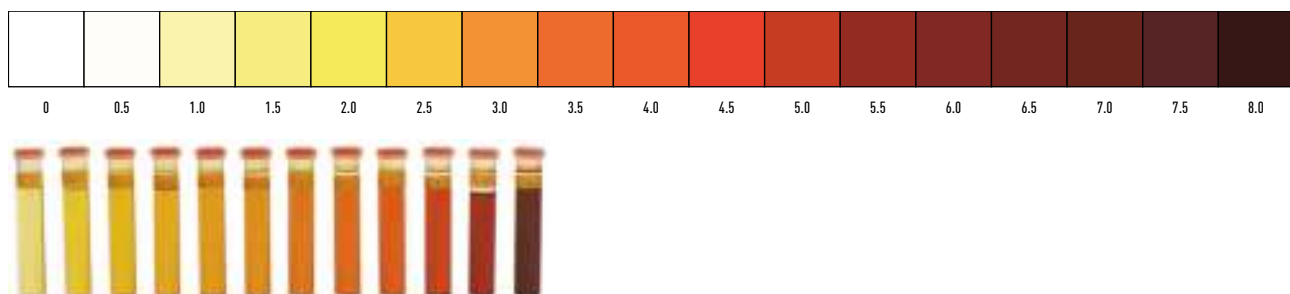

PKEA dimensions

Wall Mounted PKEA

CS-E9PKEA // CS-E12PKEA

CS-E15PKEA // CS-E18PKEA

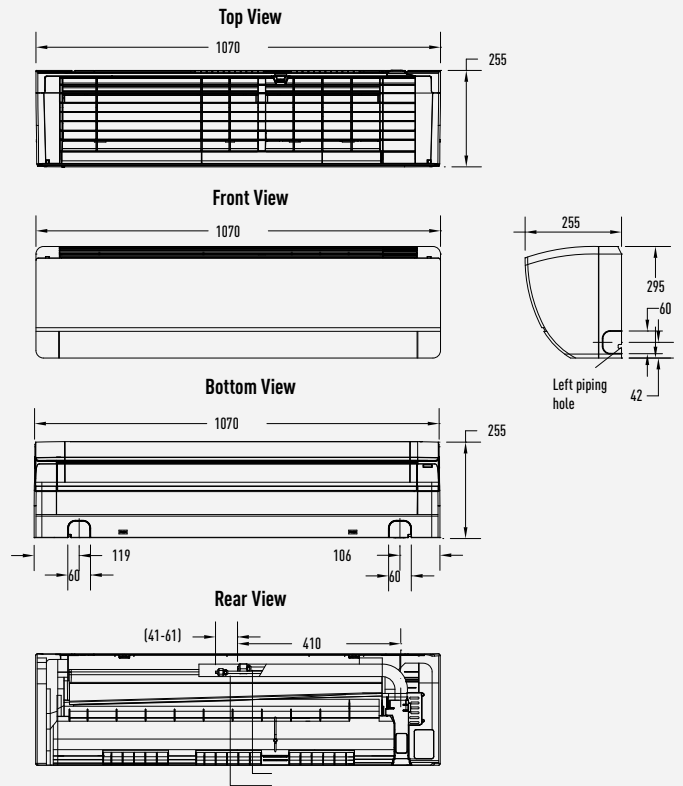
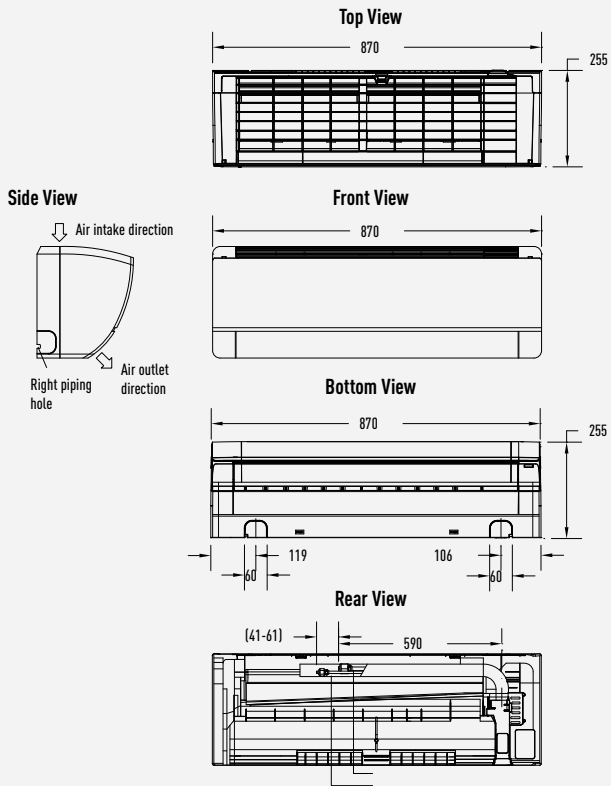

CU-E9PKEA // CU-E12PKEA

CU-E15PKEA // CU-E18PKEA

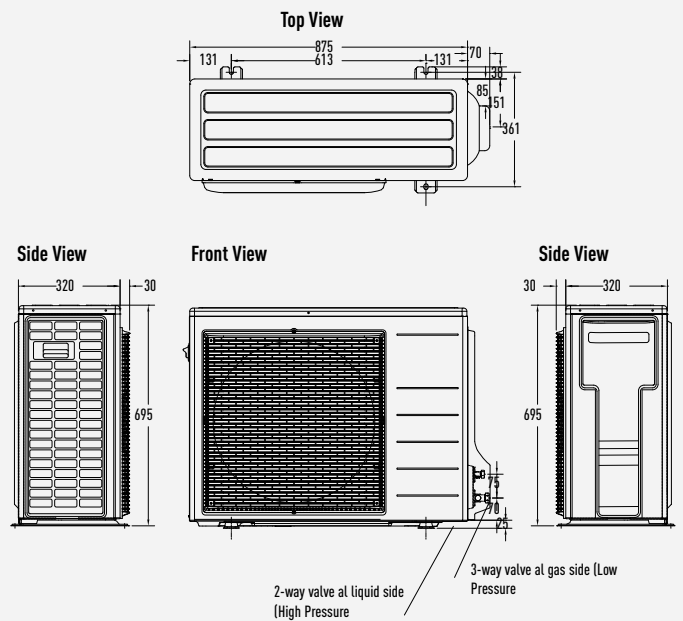
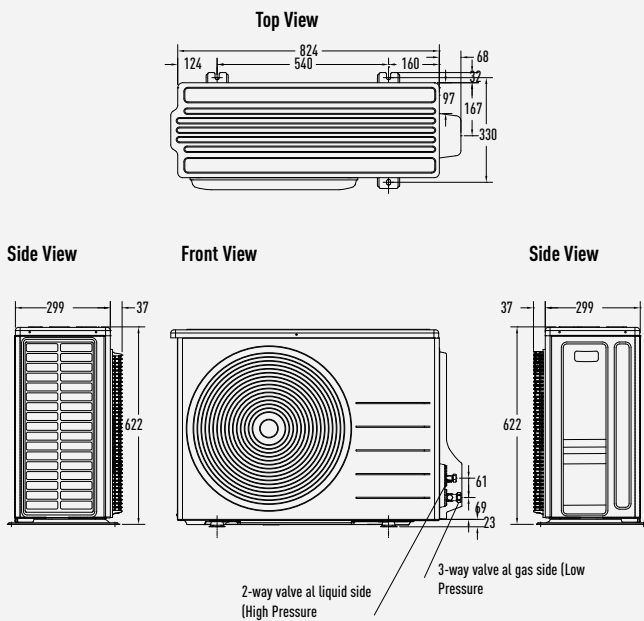

Dimensions: mm

PACi Standard and Elite dimensions

Wall

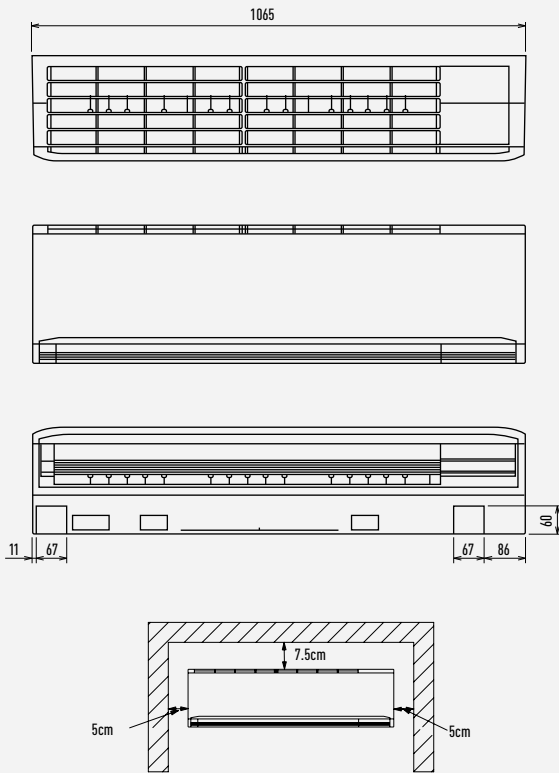

Type	36 - 50	60 - 100
1 Refrigerant tubing (liquid tube)	Ø 6,35 (flared)	Ø 9,52 (flared)
2 Refrigerant tubing (gas tube)	Ø 12,7 (flared)	Ø 15,88 (flared)
3 Drain hose VP13	Outer diameter Ø 18	
4 Rear panel	PL BACK	
5 Tubing and wiring holes	Ø 80	

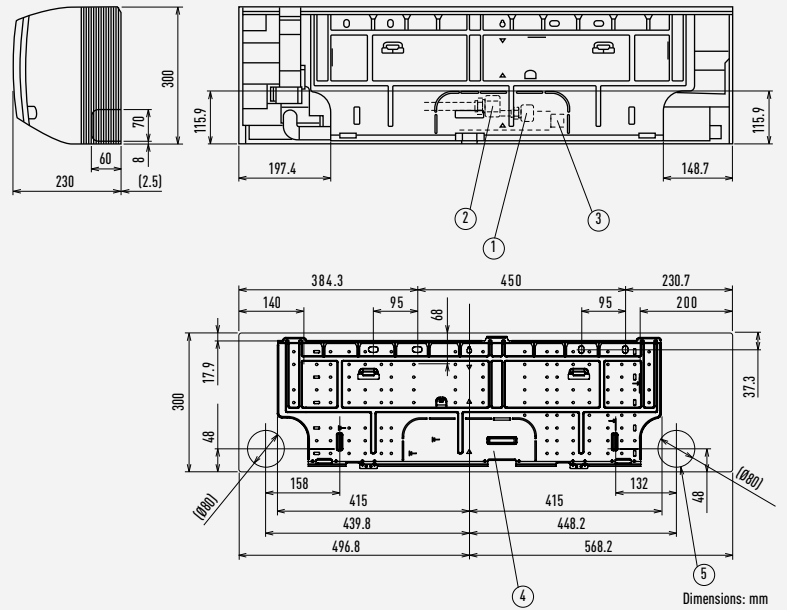

4-Way 60x60 Cassette

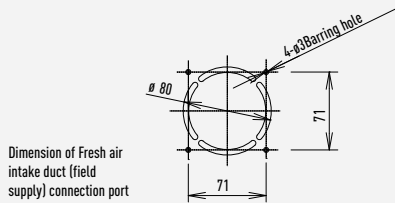
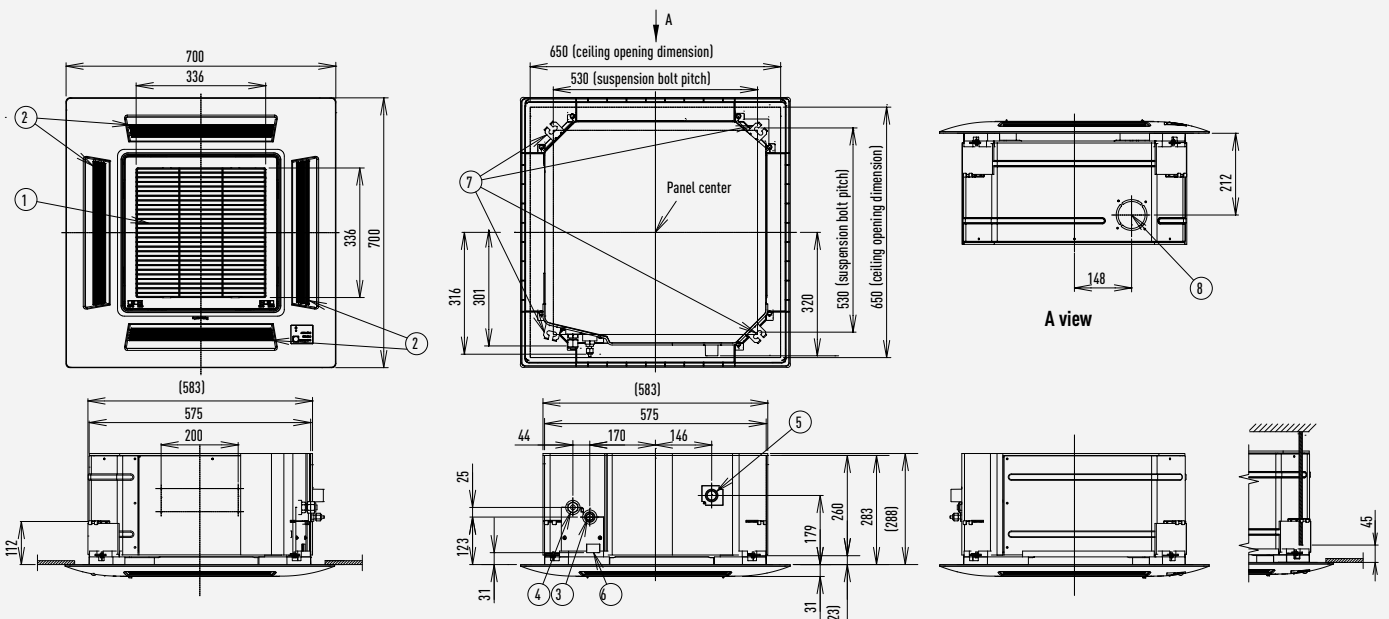

1	Air intake	
2	Discharge outlet	
3	Refrigerant tubing (liquid tube)	Ø 6,35 (flared)
4	Refrigerant tubing (gas tube)	Ø 12,7 (flared)
5	Drain tube connection port VP25	Outer dia. Ø 32
6	Power supply port	
7	Suspension bolt hole	4-11 x 26 hole
8	Fresh air intake duct connection port	Ø 80

Adjust the suspension bolt length so that the gap from the lower ceiling surface becomes 45mm or more, as shown in the figure at right. If the suspension bolts is too long, it will contact the ceiling panel and the unit cannot be installed.

Dimensions: mm

PACi Standard and Elite dimensions

4 Way 90x90 Cassette

Type	36 - 71	100 - 140
1 Air intake grill		
2 Air discharge outlet		
3 Refrigerant piping (liquid pipes)	Ø 6,35 (flared)	Ø 9,52 (flared)
4 Refrigerant piping (gas pipes)	Ø 12,7 (flared)	Ø 15,88 (flared)
5 Drain outlet VP50	Outer diameter 32mm	
6 Power supply port		
7 Discharge duct	Ø 150	
8 Suspension bolt hole	4-12x30 slot	
9 Fresh air intake duct connection port	Ø 100 ¹	

1 Air inlet kit is necessary.
Filter size: 520 x 520 x 16

Type	36 - 71	100 - 140
A	256	319
B	124	187

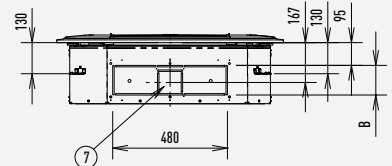
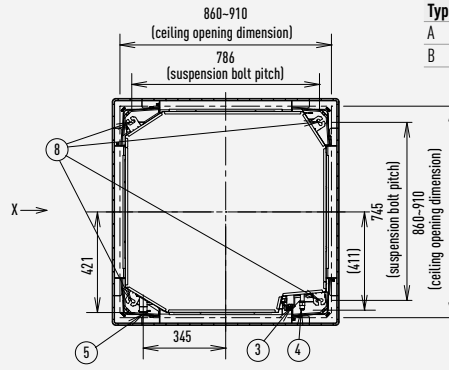

X view

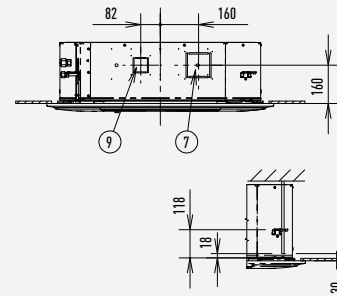
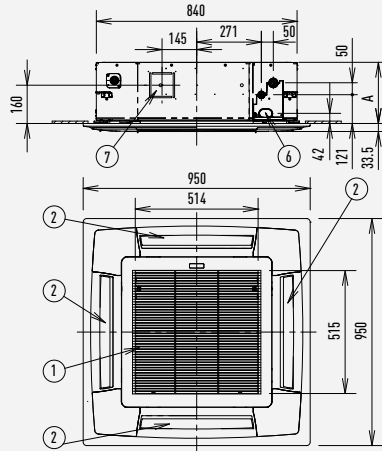
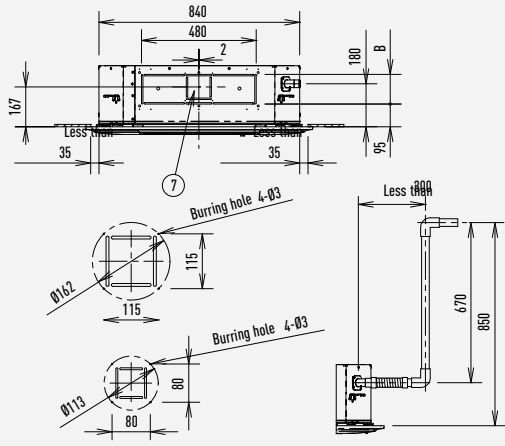

Adjust the suspension bolt length so that the gap from the lower ceiling surface becomes 30mm or more (18mm or more from the lower surface of the body) as shown in the figure. When the suspension bolt length is long, it hits the ceiling panel and installation is not possible.

Dimensions: mm

Low Static Pressure Hide Away

S-36PN1E5A // S-45PN1E5A // S-50PN1E5A

S-60PN1E5A // S-71PN1E5A

S-100PN1E5A // S-125PN1E5A // S-140PN1E5A

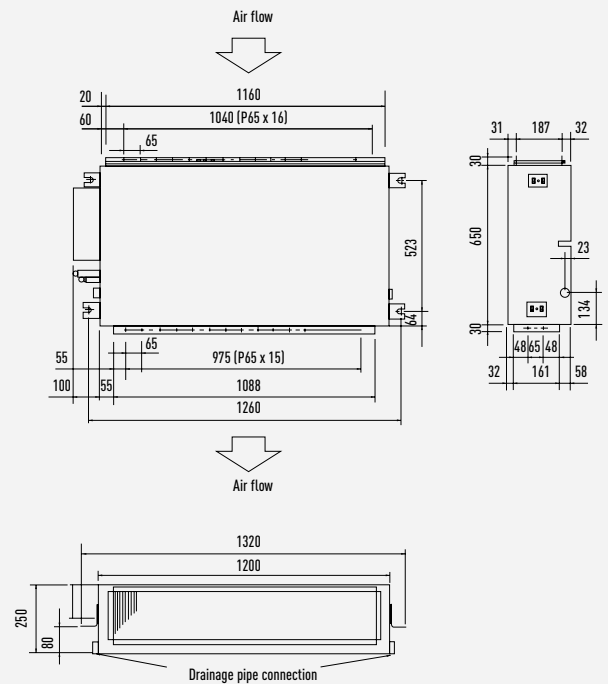
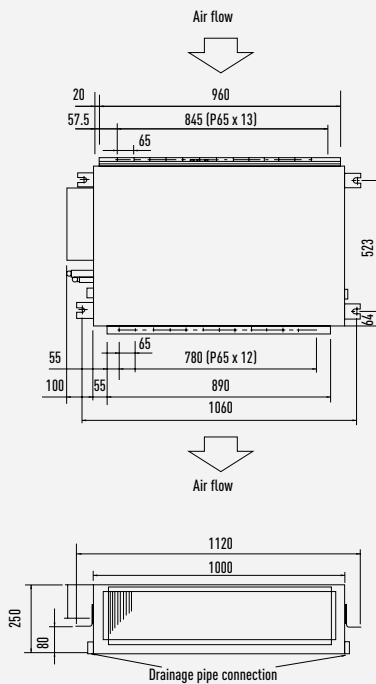
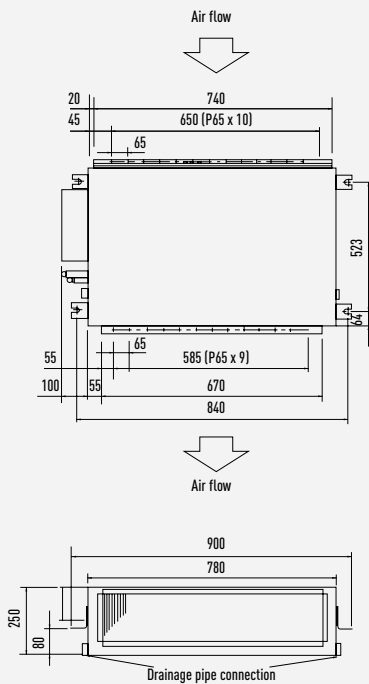

Dimensions: mm

High Static Pressure Hide Away

S-36PF1E5A // S-45PF1E5A // S-50PF1E5A

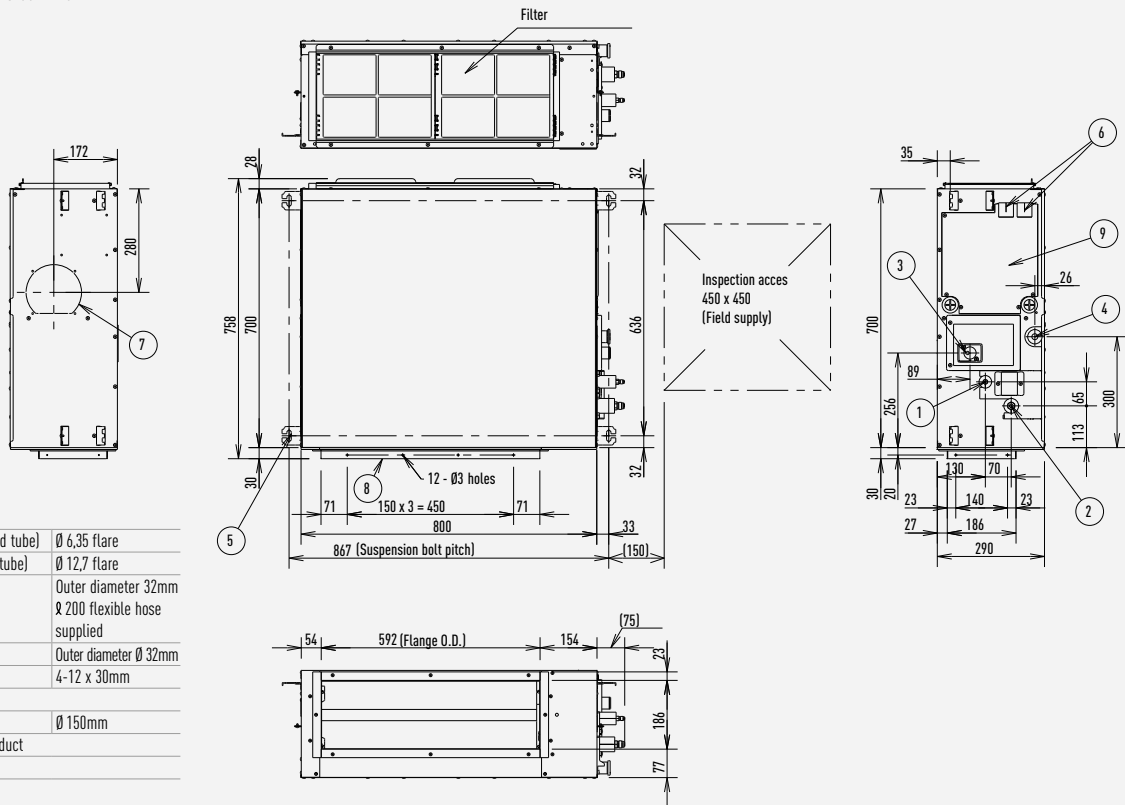

1 Refrigerant tubing joint (liquid tube)	Ø 6,35 flare
2 Refrigerant tubing joint (gas tube)	Ø 12,7 flare
3 Upper drain port VP25	Outer diameter 32mm Ø 200 flexible hose supplied
4 Bottom drain port VP 25	Outer diameter Ø 32mm
5 Suspension lug	4-12 x 30mm
6 Power supply outlet	
7 Fresh air intake port	Ø 150mm
8 Flange for flexible air outlet duct	
9 Electrical component box	

S-60PF1E5A // S-71PF1E5A

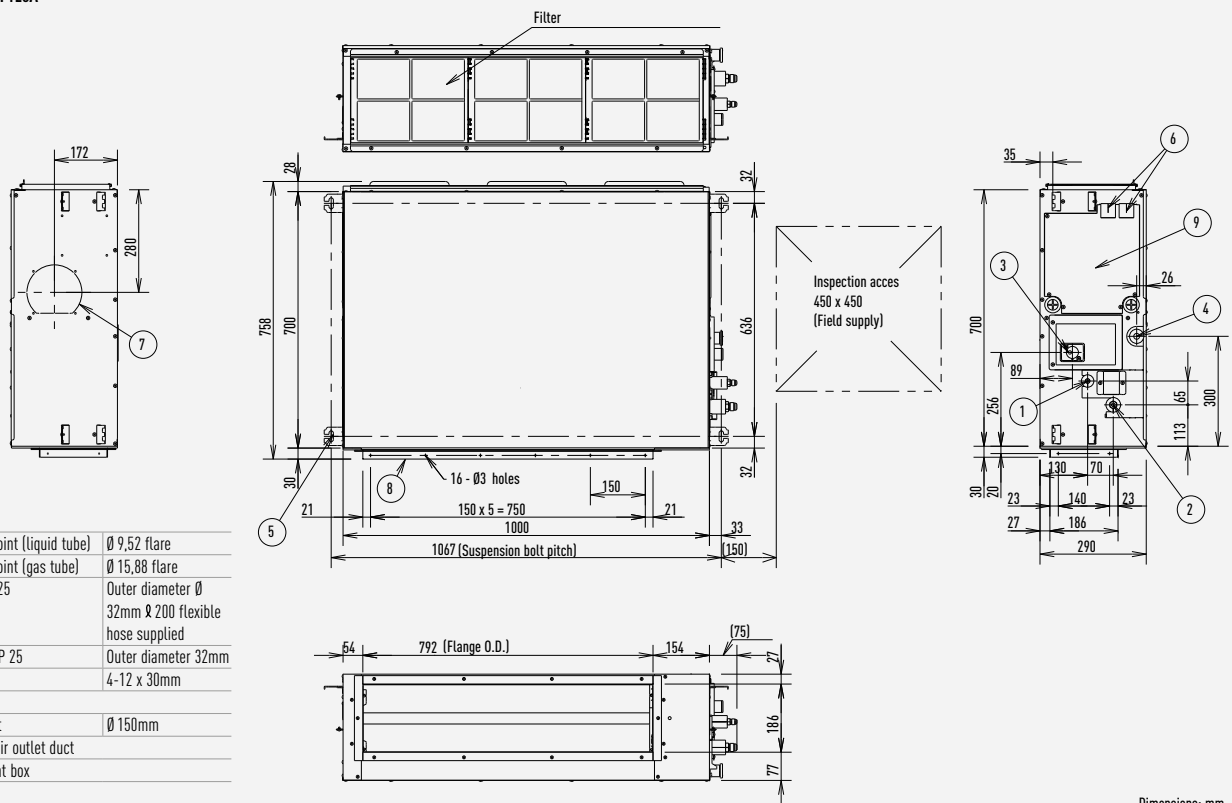

1 Refrigerant tubing joint (liquid tube)	Ø 9,52 flare
2 Refrigerant tubing joint (gas tube)	Ø 15,88 flare
3 Upper drain port VP25	Outer diameter Ø 32mm Ø 200 flexible hose supplied
4 Bottom drain port VP 25	Outer diameter 32mm
5 Suspension lug	4-12 x 30mm
6 Power supply outlet	
7 Fresh air intake port	Ø 150mm
8 Flange for flexible air outlet duct	
9 Electrical component box	

Dimensions: mm

PACi Standard and Elite dimensions

High Static Pressure Hide Away (Cont.)

S-100PF1E5A // S-125PF1E5A // S-140PF1E5A

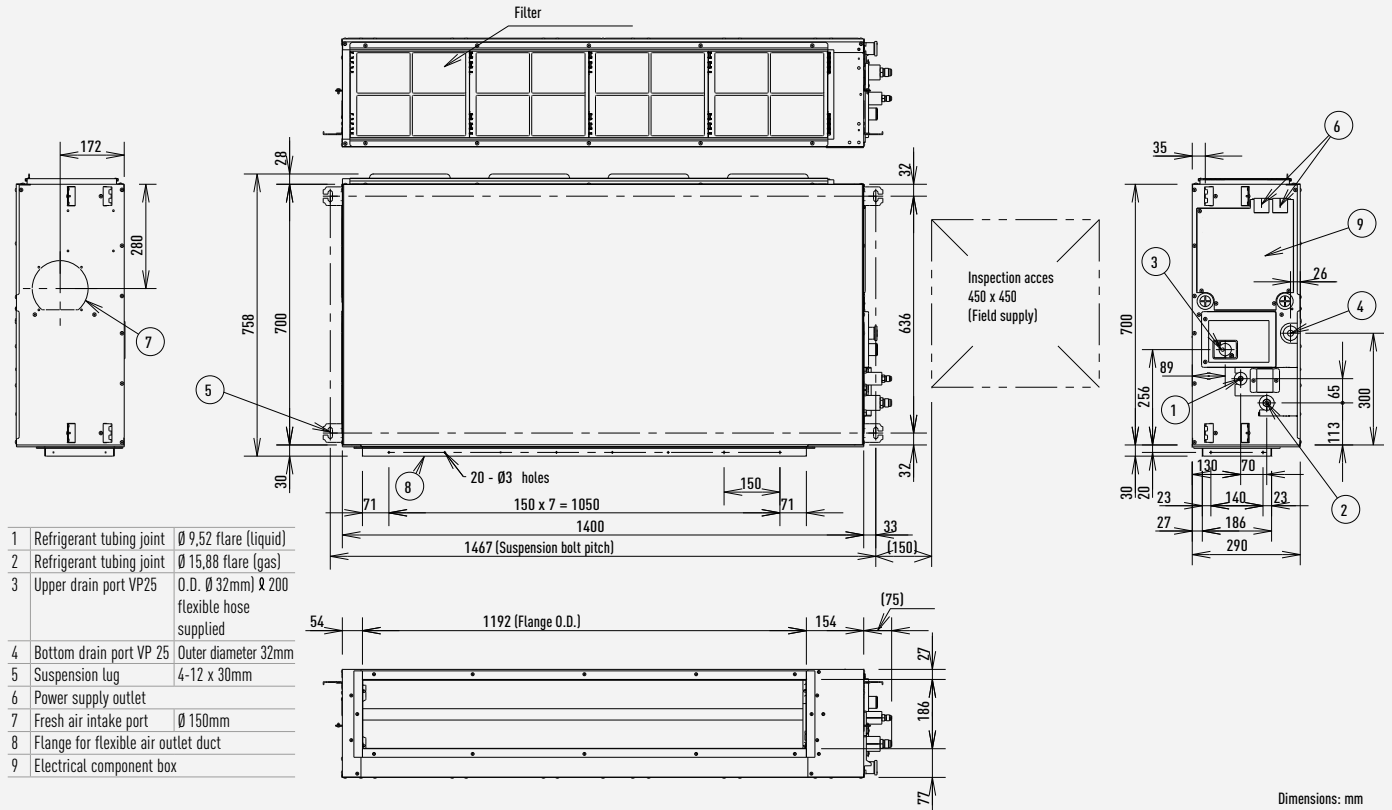

Dimensions: mm

Ceiling

S-60PT2E5A // S-71PT2E5A

1 Drain port VP20	Inside diameter Ø 26mm, drain hose supplied
2 Left drain position	
3 Refrigerant liquid tubing	Ø 9,52, flare connection
4 Refrigerant gas tubing	Ø 15,88, flare connection
5 Left side drain hose outlet port (cutout)	
6 Tubing hole on wall surface	Ø 100mm
7 Upper side tubing port	
8 Right side drain port	
9 Wireless remote controller receiver installation location	

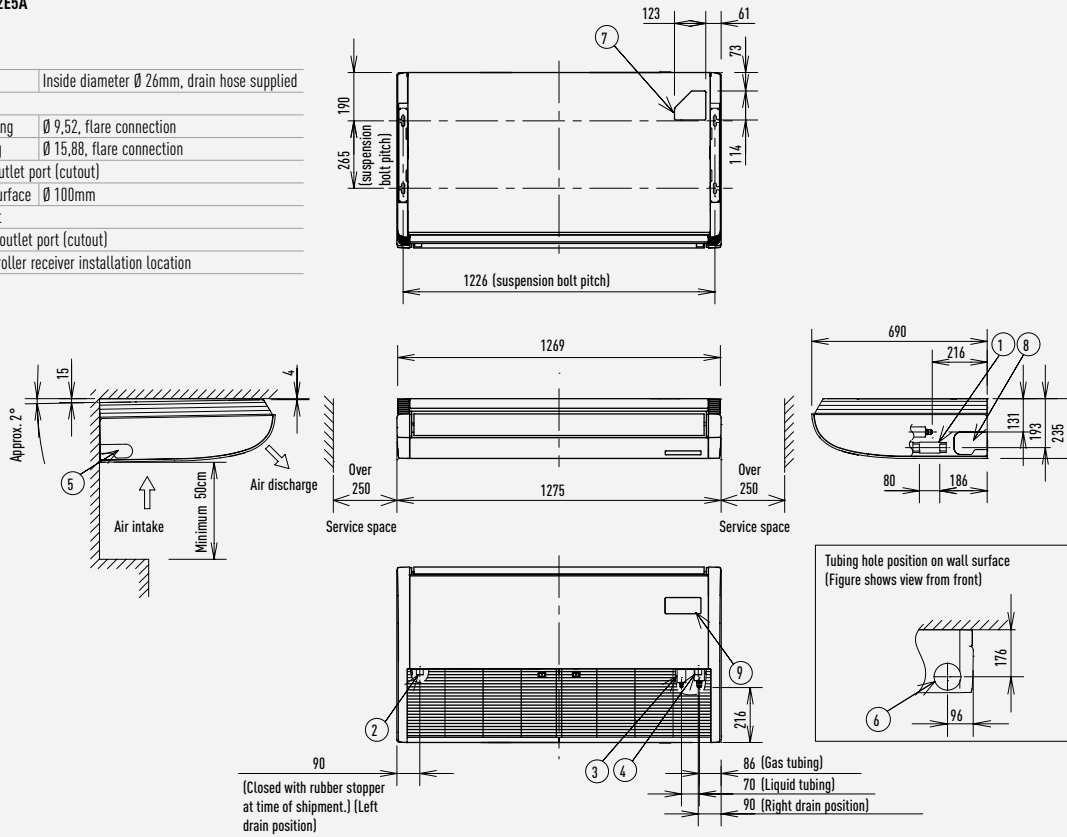

S-100PT2E5A // S-125PT2E5A // S-140PT2E5A

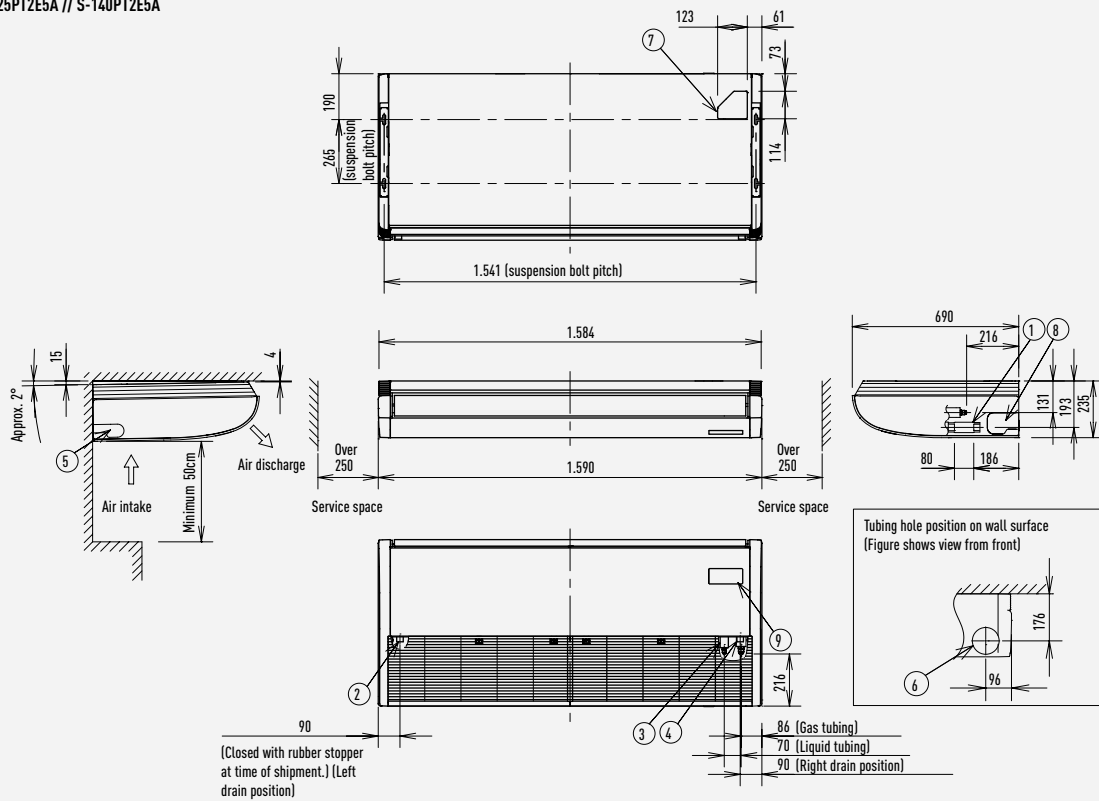

Dimensions: mm

PACi Standard and Elite dimensions

High Static Pressure Hide Away 20,0-25,0 kW

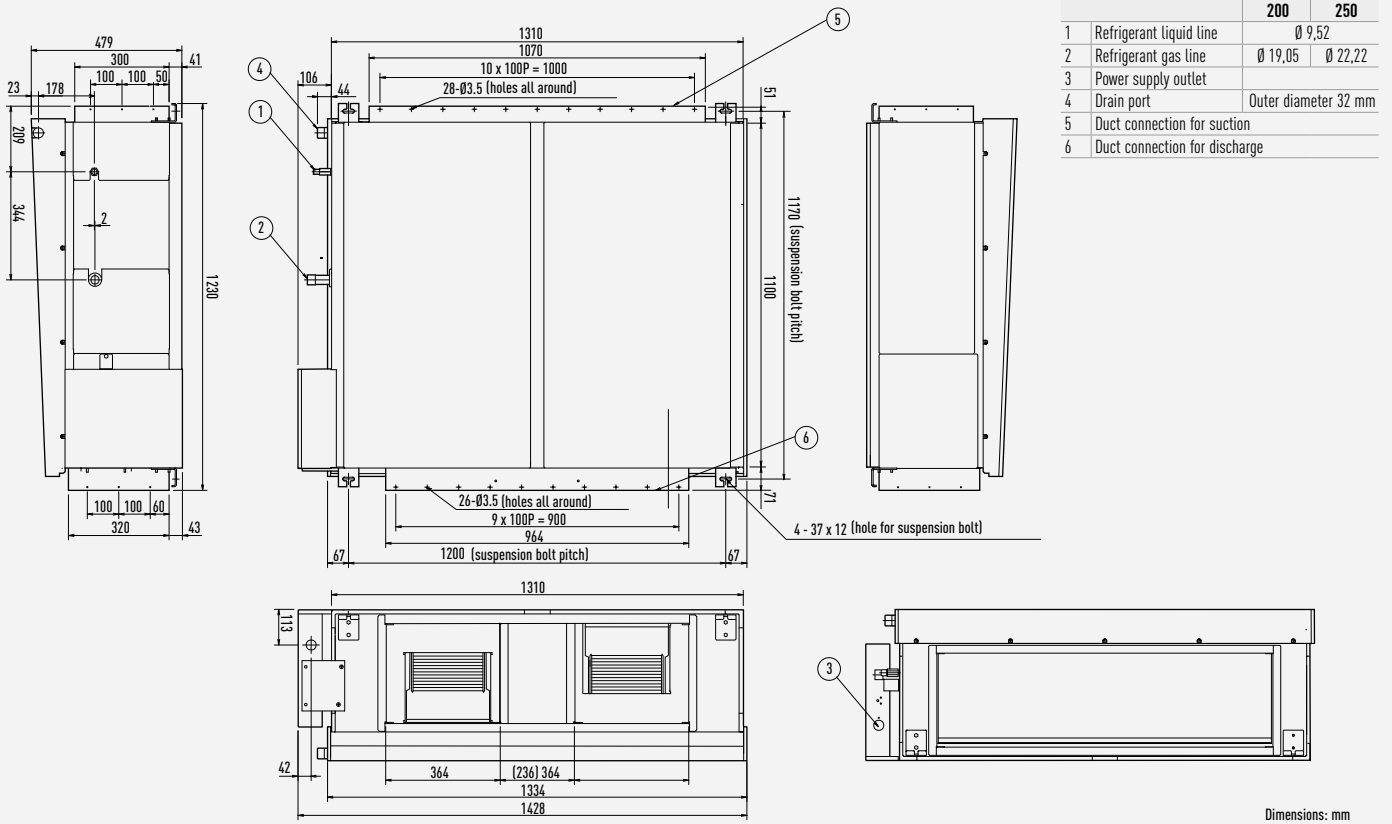

Outdoor Unit PACi Standard 6,0 and 7,1 kW and PACi Elite 5,0 kW

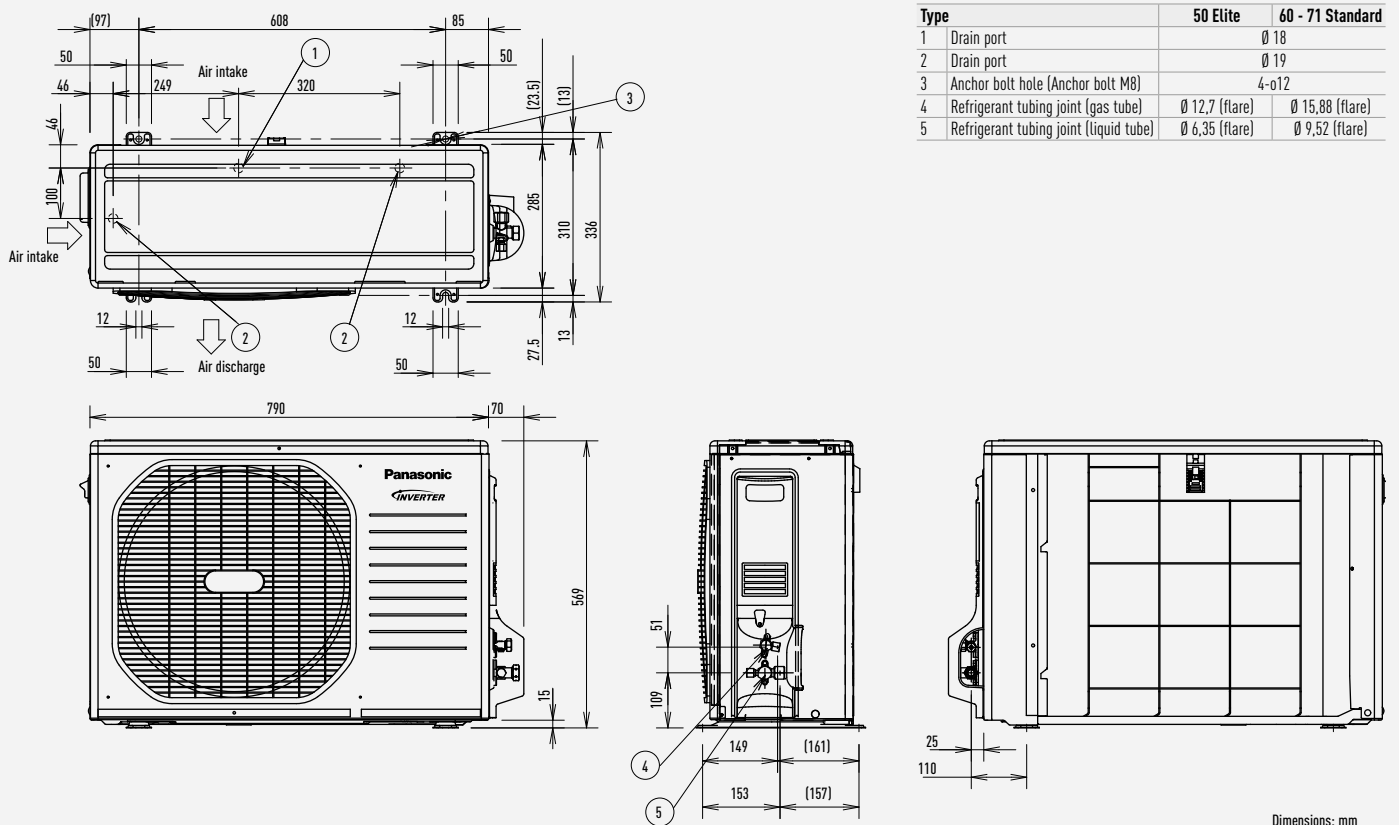

Outdoor unit PACi Standard 10,0 and 12,5 kW and PACi Elite 6,0 and 7,1 kW

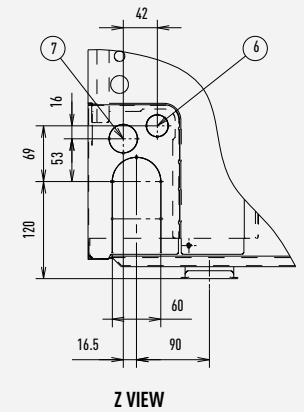
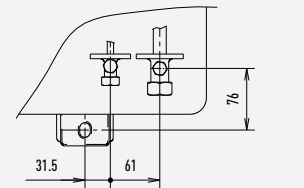
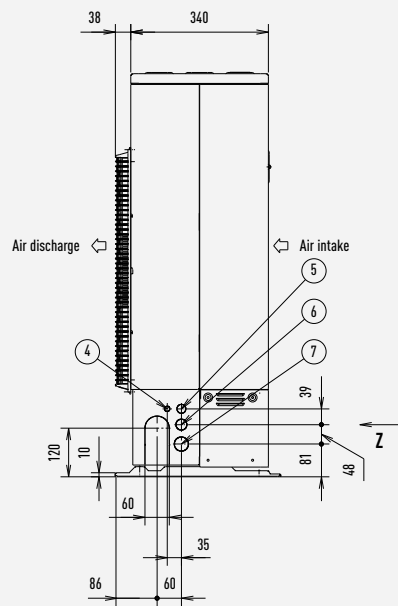
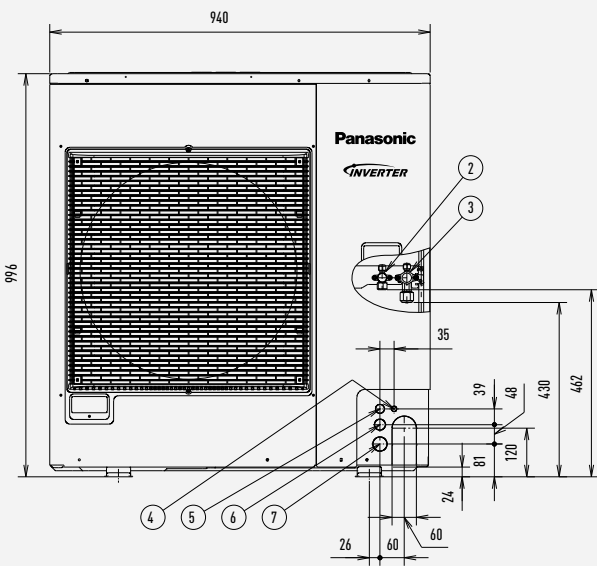
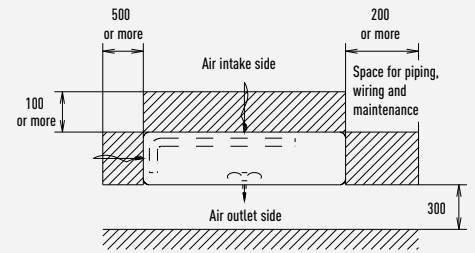
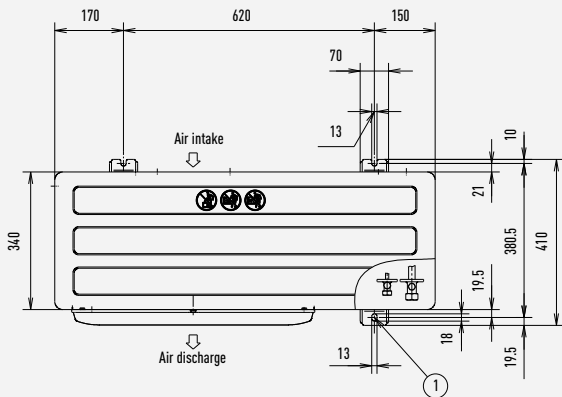

Z VIEW

Dimensions: mm

1	Mounting hole (4-R6.5), anchor bolt	M10
2	Refrigerant piping (liquid pipe)	Ø 9,52 (flared)
3	Refrigerant piping (gas pipe)	Ø 15,88 (flared)
4	Electrical wiring port	Ø 13
5	Electrical wiring port	Ø 22
6	Electrical wiring port	Ø 27
7	Electrical wiring port	Ø 35

PACi Standard and Elite dimensions

Outdoor unit PACi Standard 14,0 kW and PACi Elite from 10,0 to 14,0 kW

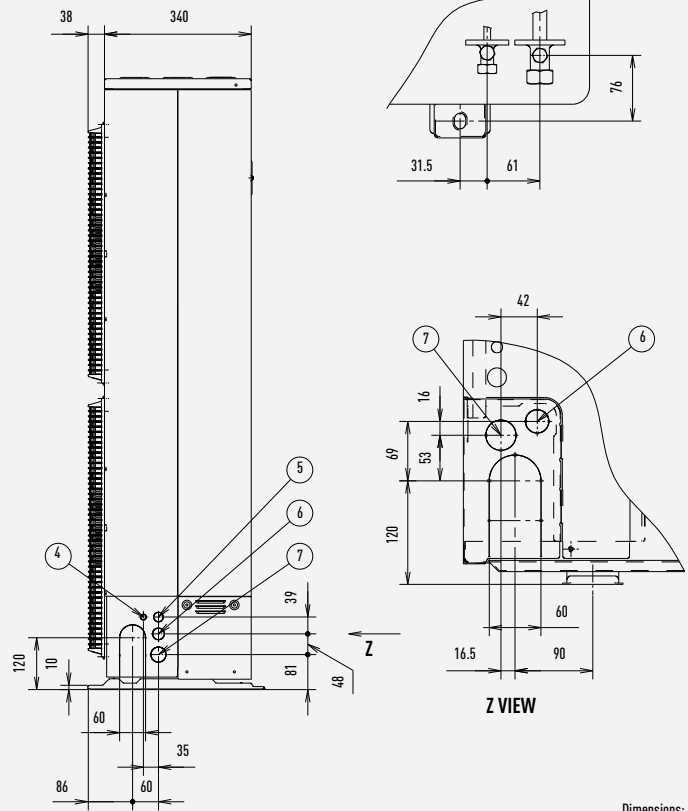
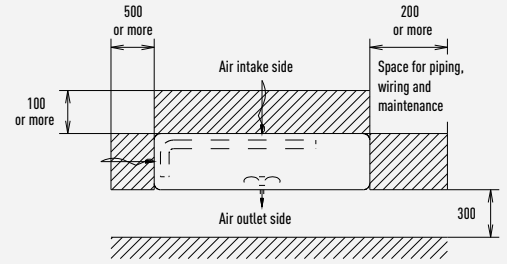
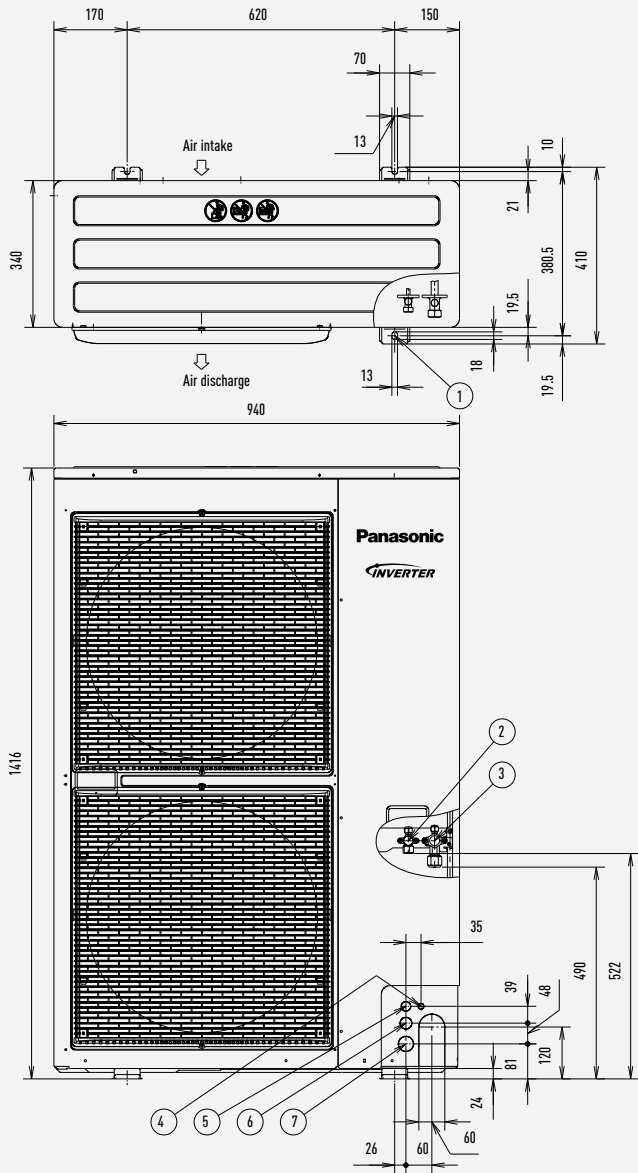

Dimensions: mm

1	Mounting hole (4-R6.5), anchor bolt	M10
2	Refrigerant piping (liquid pipe)	∅ 9,52 (flared)
3	Refrigerant piping (gas pipe)	∅ 15,88 (flared)
4	Electrical wiring port	∅ 13
5	Electrical wiring port	∅ 22
6	Electrical wiring port	∅ 27
7	Electrical wiring port	∅ 35

PACi Standard and Elite dimensions

AHU Connection Kit

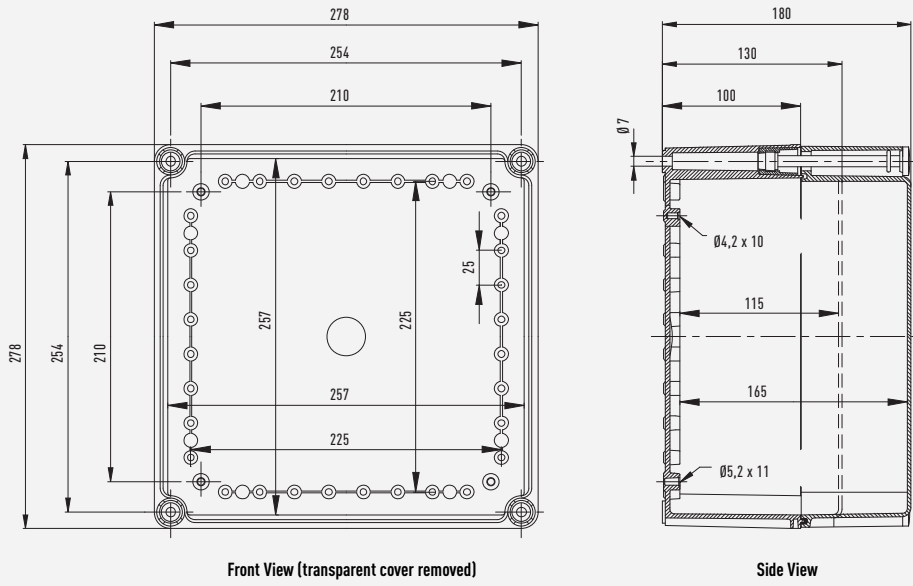

Air Curtain with DX Coil

Jet-flow dimensions

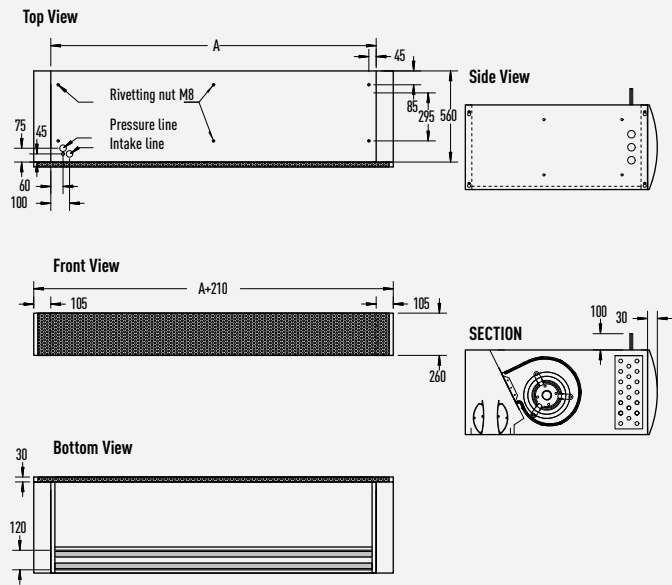

	PAW-10PAIRC-MJ	PAW-15PAIRC-MJ	PAW-20PAIRC-MJ	PAW-25EAIRC-MJ
A	1.000	1.500	2.000	2.500

Standard dimensions

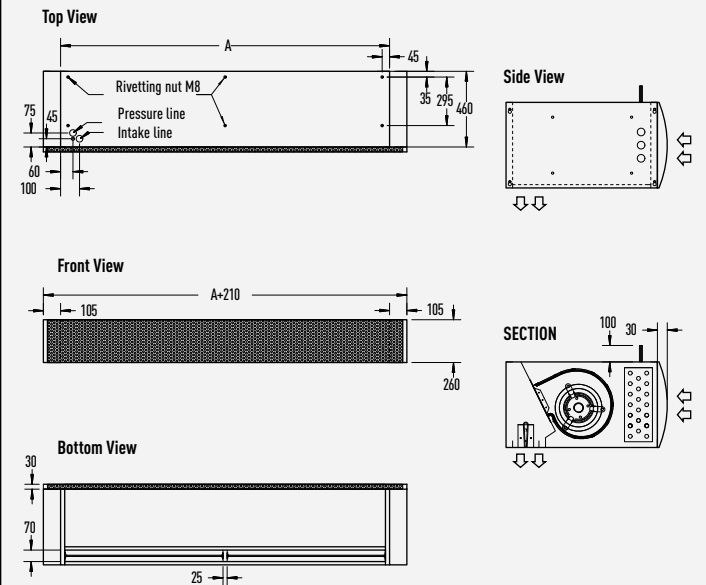

	PAW-10PAIRC-MS	PAW-20PAIRC-MS
A	1.000	2.000

Electric Air Curtain

Indoor unit dimensions FY-10ESPNAH

Front View

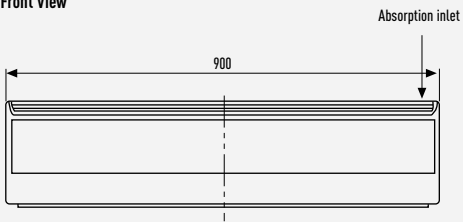

Back View

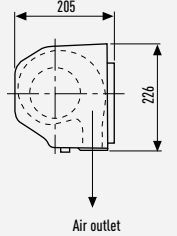
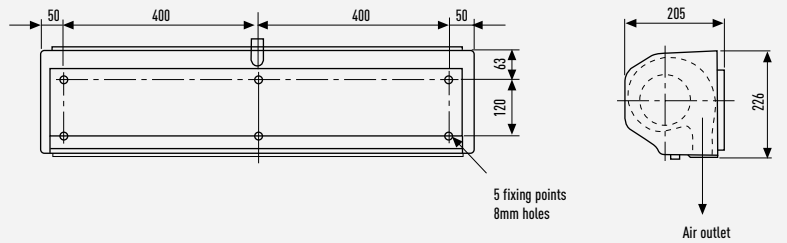

Indoor unit dimensions FY-10ELPNAH

Front View

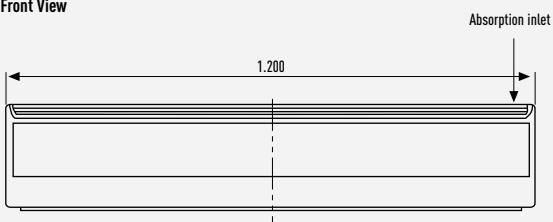

Back View

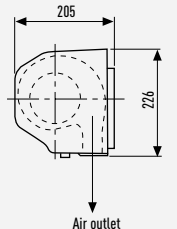
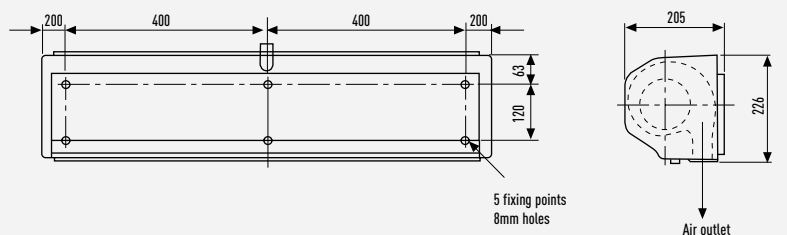

Control dimensions

PAW-SERVER-PKEA for PKEA

